

# **Assessment of Practical Skills in Science and Technology**

**Class X**

**Central Board of Secondary Education**  
Shiksha Kendra, 2, Community Centre, Preet Vihar, Delhi – 110092

---



## Contents

	Page No.
Foreword	
Introduction	5
Board's Initiative	5
List of Experiments	7
Categories of Practical Skills	9
Design of Question Paper	11
Sample Question Paper I	13
Question-wise Analysis and Scoring Key - I	27
Sample Question Paper II	29
Question-wise Analysis and Scoring Key - II	41
Sample Question Paper III	43
Question-wise Analysis and Scoring Key – III	55
Acknowledgements	58



## 1. Introduction

The crucial role of experiments in school science curriculum is universally accepted. A good science curriculum must not only give balanced emphasis to both theory and experiments but also integrate these two essential and complementary aspects of science in the teaching-learning process. Modern science, as we all know, is the result of a creative interplay of experiments, observations and theoretical inference.

There are several ways in which experiments facilitate and improve the learning of science. First and foremost, experiments help students develop the right perspective of science, namely that science is not just a theoretical abstraction – it is an attempt to describe the working of the real world around us. A hypothesis or idea in science is acceptable only if observations and experiments confirm it. Second, experiments are among the most effective ways to generate interest in science. For many students, an apparently ‘dry’, ‘uninteresting’ fact of a theory textbook can become live and exciting when translated into an experiment. Third, experiments promote the basic skills and competencies of doing science: procedural and manipulative skills, observation skills, skills of representing and interpreting data and the accompanying conceptual and critical abilities. For these various reasons, promoting activity and experiment based learning has been at the heart of many efforts aimed at improving science education in our country.

Despite several laudable efforts in the past, experiments, by and large, have continued to be marginalized in our schools. There seem to be two principal difficulties. Firstly, experiments require a certain minimum infrastructure – a laboratory with some basic equipments and consumables on a recurring basis. Secondly, assessment of practical skills in science in a sound and objective manner is by no means an easy task. The difficulty multiplies manifold if assessment is to be carried out on a large scale. Thus lack of infrastructure and, more important, lack of reliable assessment have resulted in the unfortunate neglect of experimental work in most of the schools in India.

## 2. The Board’s Initiative

The problem of neglect of experiments in our schools and of proper assessment of students in practical skills has always been a matter of great concern for the Central Board of Secondary Education. The problem assumes even greater importance for Class X, which is the terminal stage of secondary education. The Board has been keen to find out ways to promote laboratory work in our school system and has taken a number of initiatives in this direction. The Board tries to ensure that its affiliated schools have the necessary infrastructure to carry out experiments prescribed in the syllabus to Class IX and X. To make this feasible for all its schools, care is taken that the laboratory curriculum does not demand prohibitively costly equipment or other unrealistic requirements. As another important initiative to make assessment of practicals fair, uniform and reliable and to increase the

emphasis on practicals in schools, the Board introduced a new scheme of assessment for Class IX from the academic year 2005-06. A document giving detailed guidelines on the new scheme of assessment of practicals with sample question papers was brought out by the Board. This was done to ensure that practicing teachers understood the new scheme clearly and were sensitized and oriented to the same before it was introduced for the more critical Class X stage. The positive experience and feedback to the new scheme for Class IX have convinced the Board that this is a step in the right direction. Accordingly, the present document reiterates the detailed guidelines of the Class IX document and gives sample question papers and related matters concerning the syllabus of practicals for Class X. In view of the critical importance of Class X stage, an even greater care has been taken that the new scheme is fair and realistic, does not cause hardship to any student or school, and promotes uniform and reliable assessment of practical skills.

As per the new scheme, theory and practical examination will have a weightage of 60% and 40% respectively. The practical examination will comprise of two components. One component of this practical examination will be in the form of a multiple choice type theory paper test, to be conducted by the Board in Class X as an independent paper. This question paper will be of 20 marks and 1 ½ hour duration. It will aim at testing of practical skills through multiple-choice type questions. Each multiple-choice question will have four options, with only one of them as the correct option. The second component will also have a weightage of 20 marks but will be conducted at school level on the lines being followed presently.

The Board hopes that this initiative will be an important step not only to give experiments their due place in the subject of Science and Technology but also to promote, in general, an experimental culture in our school system.

## LIST OF EXPERIMENTS (Class X)

1. To find the pH of the following samples by using pH paper/universal indicator.

- i) Dilute Hydrochloric acid
- ii) Dilute NaOH solution
- iii) Dilute Ethanoic acid solution
- iv) Lemon juice
- v) Water
- vi) Dilute Sodium Bicarbonate Solution.

2. To study the properties of acids and bases (dilute HCl & dilute NaOH) by their reaction with

- i) Litmus solution (Blue/Red)
- ii) Zinc metal
- iii) Solid Sodium Carbonate

3. To determine the focal length of a

- a Concave mirror
  - b Convex lens
- by obtaining the image of a distant object.

4. To trace the path of a ray of light, passing through a rectangular glass slab, for different angles of incidence. Measure the angle of incidence, angle of refraction, angle of emergence and interpret the results.

5. To study the dependence of current (I) on the potential difference (V) across a resistor and determine its resistance. Also plot a graph between V and I.

6. To determine the equivalent resistance of two resistors when connected in series.

7. To determine the equivalent resistance of two resistors when connected in parallel.

8. To prepare a temporary mount of a leaf peel to show stomata.

9. To show experimentally that light is necessary for photosynthesis.

10. To show experimentally that carbon dioxide is given out during respiration.

11. To study (a) binary fission in Amoeba and (b) budding in yeast with the help of prepared slides.

12. To determine the percentage of water absorbed by raisins.

13. To prepare SO<sub>2</sub> gas, observe its following properties and draw inferences in respect of

- i) odour
- ii) solubility in water
- iii) effect on litmus paper
- iv) action on acidified potassium dichromate solution.

14. a) To observe the action of Zn, Fe, Cu and Al metals on the following salt solutions.

- i) ZnSO<sub>4</sub> (aq.)
- ii) FeSO<sub>4</sub> (aq.)
- iii) CuSO<sub>4</sub> (aq.)
- iv) Al<sub>2</sub>(SO<sub>4</sub>)<sub>3</sub> (aq.)

b) Arrange Zn, Fe, Cu and Al metals in the decreasing order of reactivity based on the above result.

15. To study the following properties of acetic acid (ethanoic acid):

- i) odour
- ii) solubility in water
- iii) effect on litmus
- iv) reaction with sodium bicarbonate

??

??

??

??

1



## CATEGORIES OF PRACTICAL SKILLS

### A. Procedural and Manipulative Skills

To

- ? select appropriate apparatus / instruments for performing the experiment.
- ? Know the limitations of the apparatus/instruments regarding their size, least count and accuracy.
- ? arrange / assemble / set and adjust the apparatus systematically.
- ? handle the apparatus, instruments, chemicals carefully to avoid any damage or injury.
- ? perform the experiment with reasonable efficiency and accuracy.
- ? separate and remove desired parts of a specimen for detailed study without damaging it.
- ? use appropriate methods and materials for specimen mounting.
- ? locate and rectify the errors in apparatus, instruments, etc.
- ? add chemicals in appropriate quantity.
- ? dismantle the experimental set-up carefully.
- ? practise the precautions in handling sensitive apparatus or chemicals or flame.

### B. Observational Skills

To

- ? find the least count of the instrument.
- ? read the instrument correctly.
- ? notice colour change, evolution of gases, formation of precipitates, chemical reactions, etc, carefully.
- ? notice the relevant details in the given specimens minutely.
- ? locate the desired parts in a specimen accurately.
- ? take observations carefully and in a systematic manner.

? read graph correctly.

### C. Drawing Skills

To

? make proper observation tables.

? draw circuit diagrams, ray diagrams, experimental set-ups, sketches, etc. correctly and proportionately.

? label sketches and diagrams correctly.

? draw graphs from observed data correctly.

### D. Reporting and Interpretative Skills

To

? make a proper plan for recording the observations.

? record the observations/data/information correctly and systematically.

? classify and categorize organisms.

? make correct calculations/predictions.

? use proper formulae and mode of summarizing and reporting the result.

? report the result using correct symbols, units, terms and chemical equations.

? interpret the observations and results correctly.

\*\_ \*\_ \*\_ \*\_ \*\_ \*\_ \*\_ \*

## DESIGN OF THE QUESTION PAPER

Science and Technology (Class X)

Testing of Skills (Multiple Choice Type Test)

Time allotted: 1 hour 30 minutes

Max. Marks: 20

S.No.	Unit	Relevant Experiments in the syllabus	Marks allotted
1.	Chemical Reactions and Some Important Chemical Compounds	1, 2	2.5
2.	Energy	3, 4, 5, 6, 7	6.5
3.	Life Processes	8, 9, 10, 11, 12	7.0
4.	Natural Resources	13, 14, 15	4.0

### A. UNIT-WISE WEIGHTAGE

### B. SKILL-WISE WEIGHTAGE

Skill	Weightage
Procedural and Manipulative Skills	35%
Observational Skills	35%
Drawing Skills	15%
Reporting and Interpretative Skills	15%
<b>Total</b>	<b>100%</b>

Most questions involve multiple skills and it may not be possible to precisely assign a particular skill to a specific question. The skill-wise weightage given in the table below, may, therefore, be considered as only indicative of what is required in the question paper.



## Sample Question Paper I

Time: 1 ½ hours

Maximum Marks: 20

### INSTRUCTIONS

1. Attempt all questions.
2. There are 30 multiple choice questions in total. Only one of the options in every question is correct.
3. The question paper consists of two parts – Section A and Section B. Each of the 20 questions in Section A carries 0.5 mark and each of the 10 questions in Section B carries 1.0 mark.

### SECTION - A

1. The two colours seen at the extreme ends of the pH chart are
    - (a) red and blue.
    - (b) red and green.
    - (c) green and blue.
    - (d) orange and green.
  
  2. A student observed that the colour of pH paper changes to green when she dipped it in water. She added a few drops of concentrated hydrochloric acid to the water. The colour of pH paper would turn to
    - (a) light red.
    - (b) apple green.
    - (c) dark blue.
    - (d) lemon yellow.
  
  3. When zinc reacts with dilute hydrochloric acid
    - (a) the surface of zinc becomes brighter.
    - (b) the surface of zinc becomes black and dull.
    - (c) the metal turns into powder.
    - (d) the reaction mixture turns green.
-

4. Four students A, B, C and D carried out measurements of focal length of a concave mirror as shown in the four diagrams.

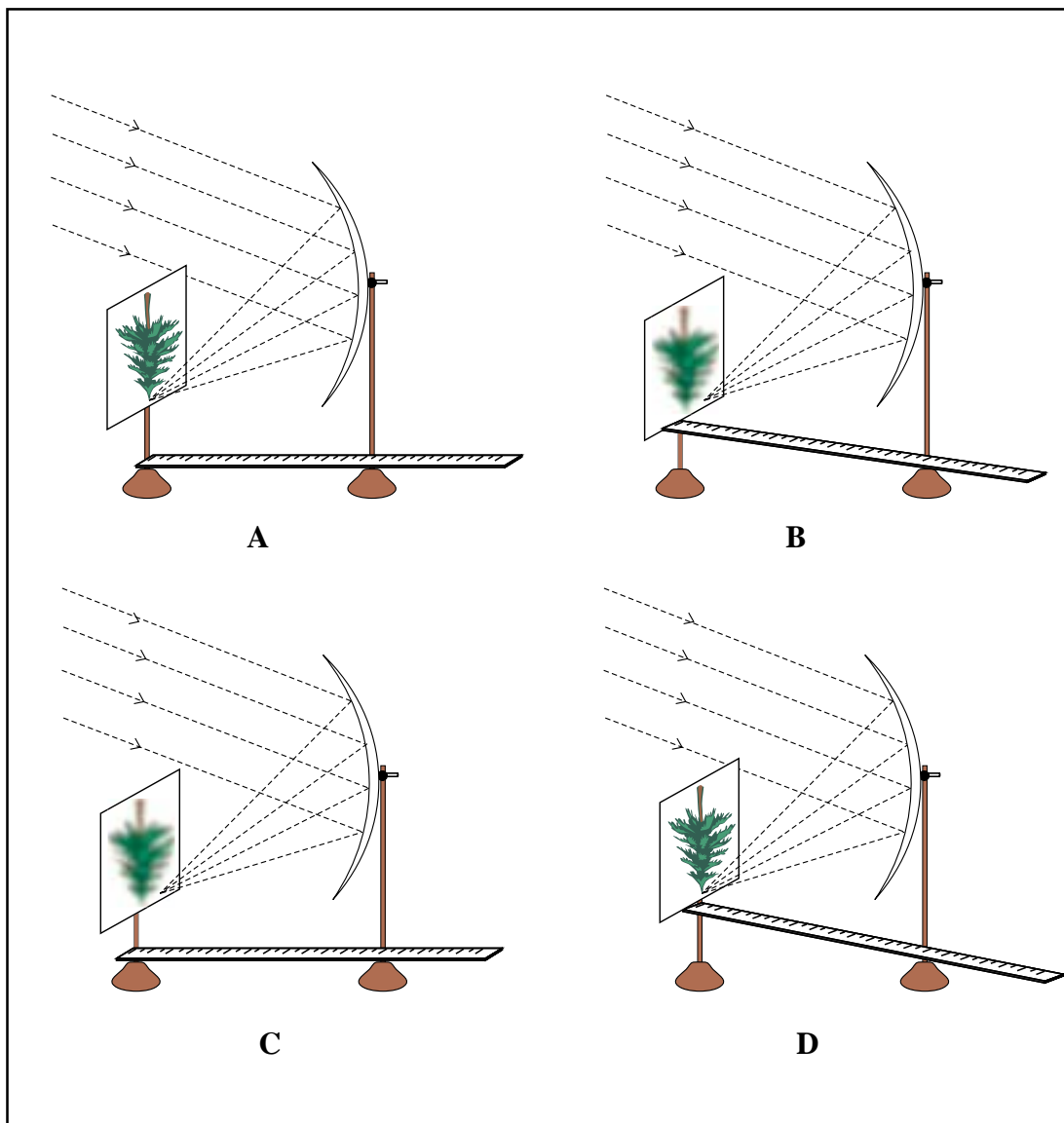

The best result will be obtained by student

- (a) A.
- (b) B.
- (c) C.
- (d) D.

5. Three students measured the focal length of a convex lens using parallel rays from a distant object. All of them measured the distance between the lens and the inverted image on the screen.

Student A saw a sharp image on the screen and labelled the distance as  $f_1$ .

Student B saw a slightly larger blurred image on the screen and labelled the distance as  $f_2$ .

Student C saw a slightly smaller blurred image on the screen and labelled the distance as  $f_3$ .

The relation between the three measurements would most likely be

- (a)  $f_1 = f_2 = f_3$ .
- (b)  $f_1 < f_2$  and  $f_3$ .
- (c)  $f_3 < f_1 < f_2$ .
- (d)  $f_1 < f_2$  and  $f_1 = f_3$ .

6. In the glass slab experiment shown below, four students A, B, C and D did the following:

A: kept the eyes far from the glass slab while placing both the pins  $P_3$  and  $P_4$ .

B: kept the eyes close to the glass slab while placing both the pins  $P_3$  and  $P_4$ .

C: kept the eyes close to the glass slab while placing pin  $P_3$  and far from the slab while placing pin  $P_4$ .

D: kept the eyes far from the glass slab while placing pin  $P_3$  and close to the slab while placing pin  $P_4$ .

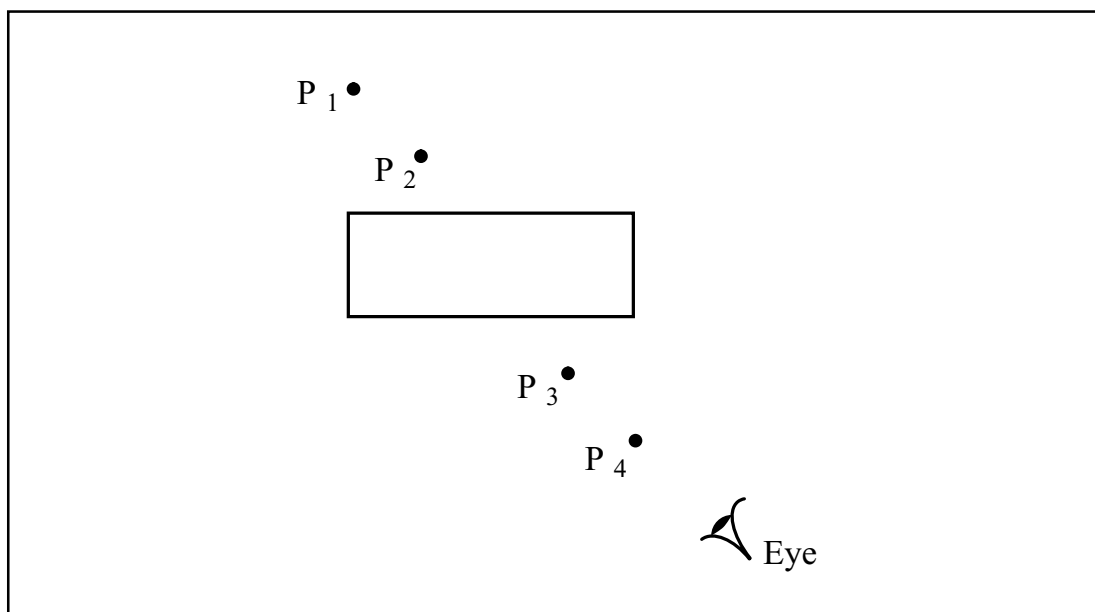

The correct procedure is that of student

- (a) A.
- (b) B.
- (c) C.
- (d) D.

7. Out of the four circuits shown for studying the dependence of the current on the potential difference across a resistor, the correct circuit is

- (a) A.
- (b) B.
- (c) C.
- (d) D.

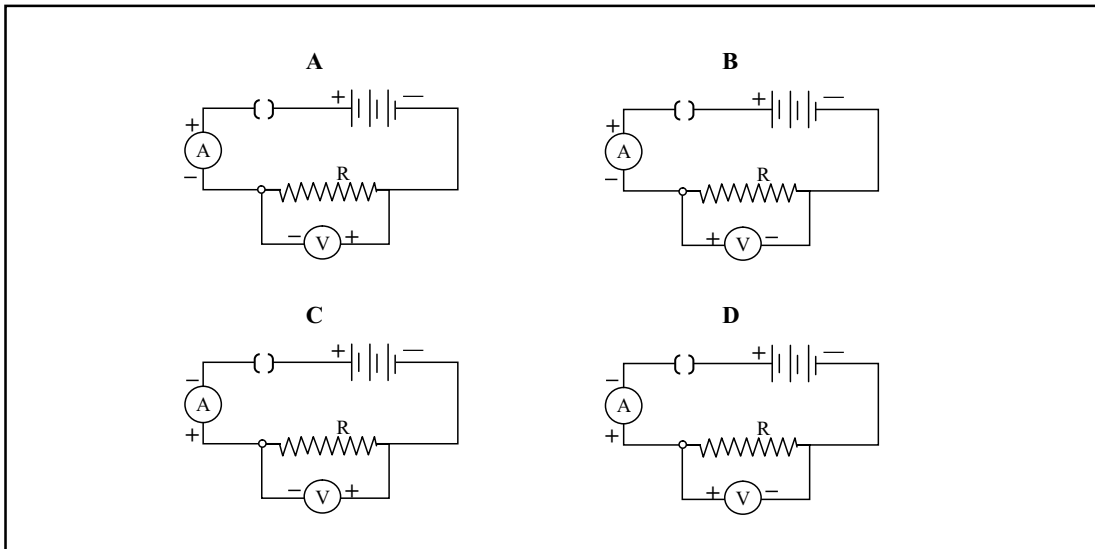

8. The plot correctly showing the dependence of the current  $I$  on the potential difference  $V$  across a resistor  $R$  is

- (a) A.
- (b) B.
- (c) C.
- (d) D.

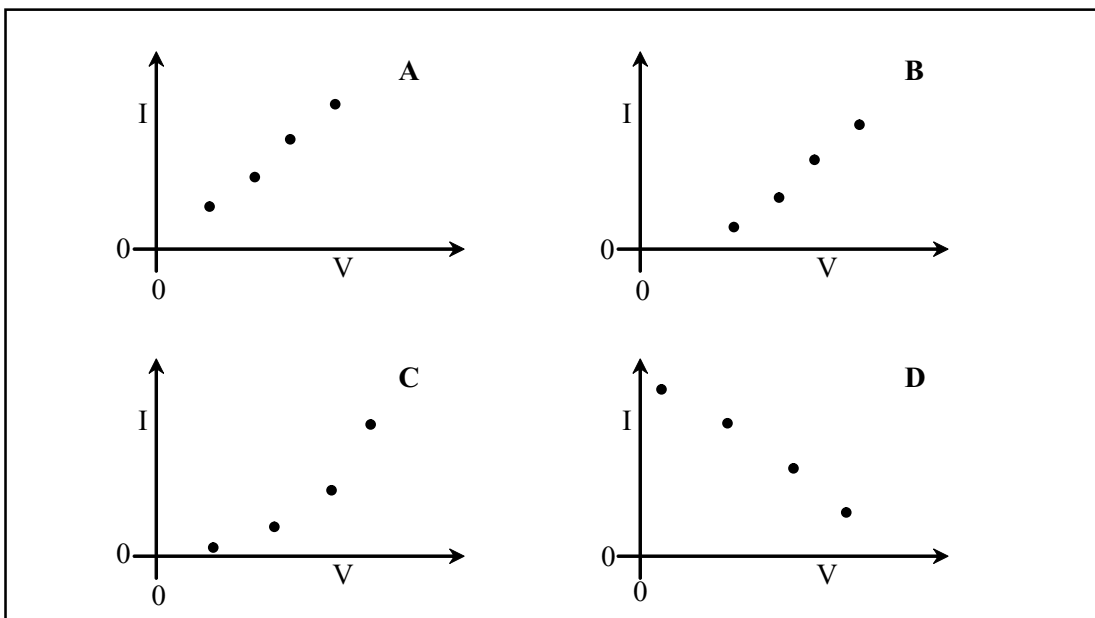



9. For the circuits shown in figures I and II, the ammeter readings would be

- (a) 1 A in circuit I and 0A in circuit II.
- (b) 0 A in both circuits.
- (c) 1 A in both circuits.
- (d) 0 A in circuit I and 1 A in circuit II.

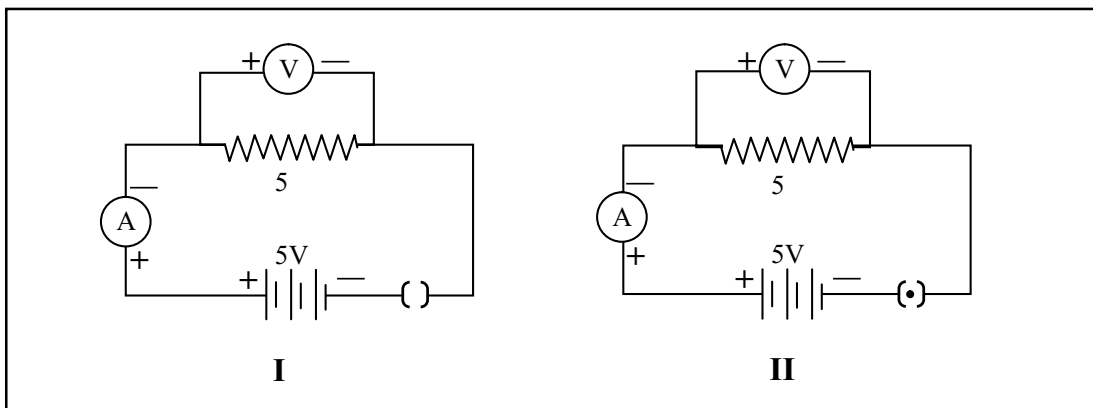

10. The voltmeter, ammeter and resistance in the circuit shown have been checked to be correct. On plugging the key, the ammeter reads 0.9 A, but the voltmeter reads zero. This could be because

- (a) the range of the voltmeter is more than the twice the battery voltage.
- (b) the least count of the voltmeter is too high.
- (c) the wires joined to the voltmeter terminals are loose.
- (d) the voltmeter is incorrectly placed in the circuit.

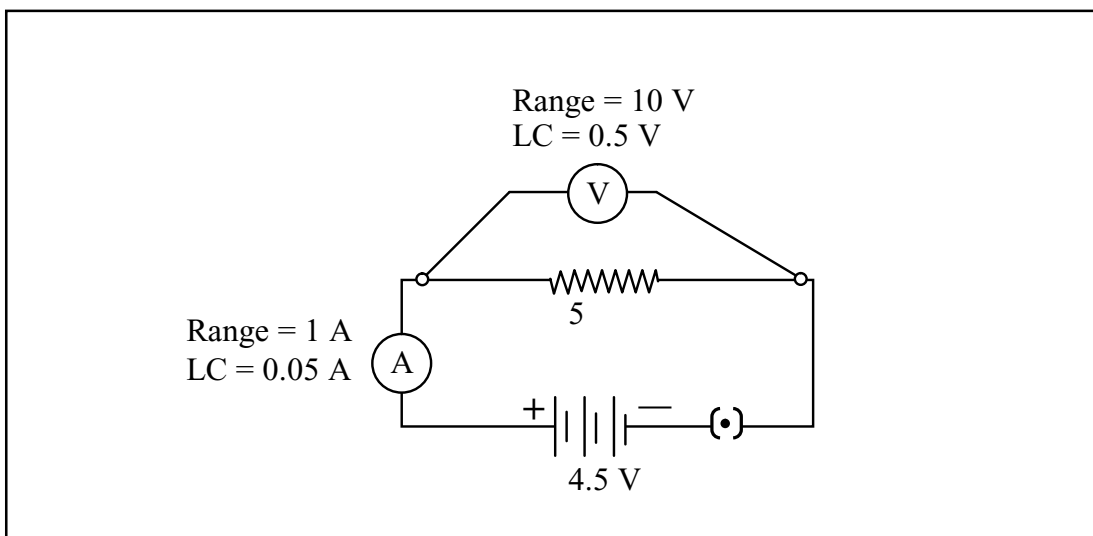

11. Students observed the epidermal peel of a leaf under the high power of a microscope. The following are the sketches made by them.

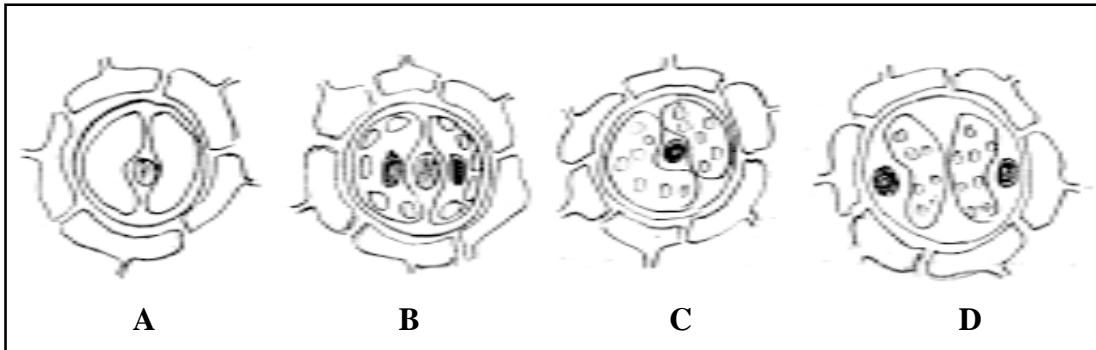

The correct sketch is

- (a) A.
- (b) B.
- (c) C.
- (d) D.

12. In an experiment on photosynthesis, students were instructed to cover a portion of a leaf of a de-starched potted plant with opaque paper as shown in the figure.

“A” covered one of the leaves with red strip, “B” with green, “C” with blue and “D” with black. When the starch test was done on the leaves after 4 hours, the result showed no starch in

- (a) the portion covered with red, green and blue strips.
- (b) the portion covered with green strip.
- (c) the portion covered with black and blue strips.
- (d) any of the covered portions.

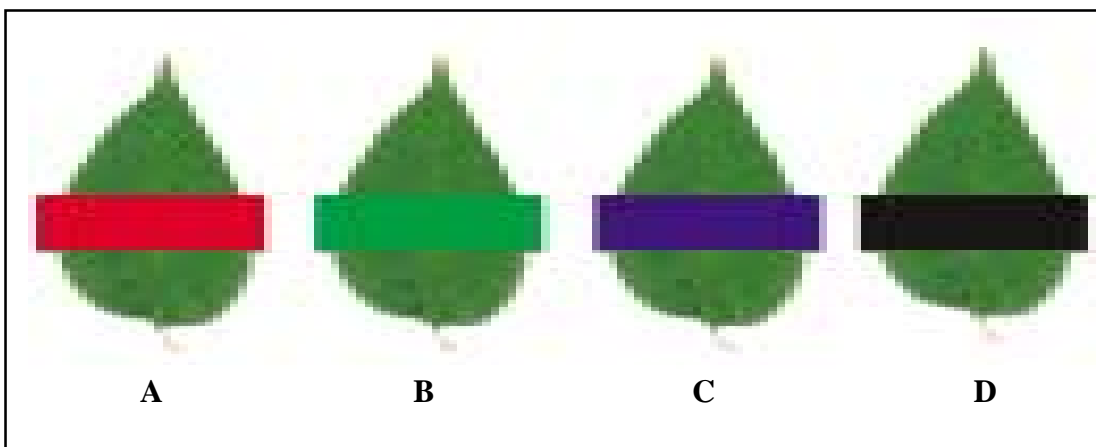

13. Given below are four different set ups to show that  $\text{CO}_2$  is released during respiration.

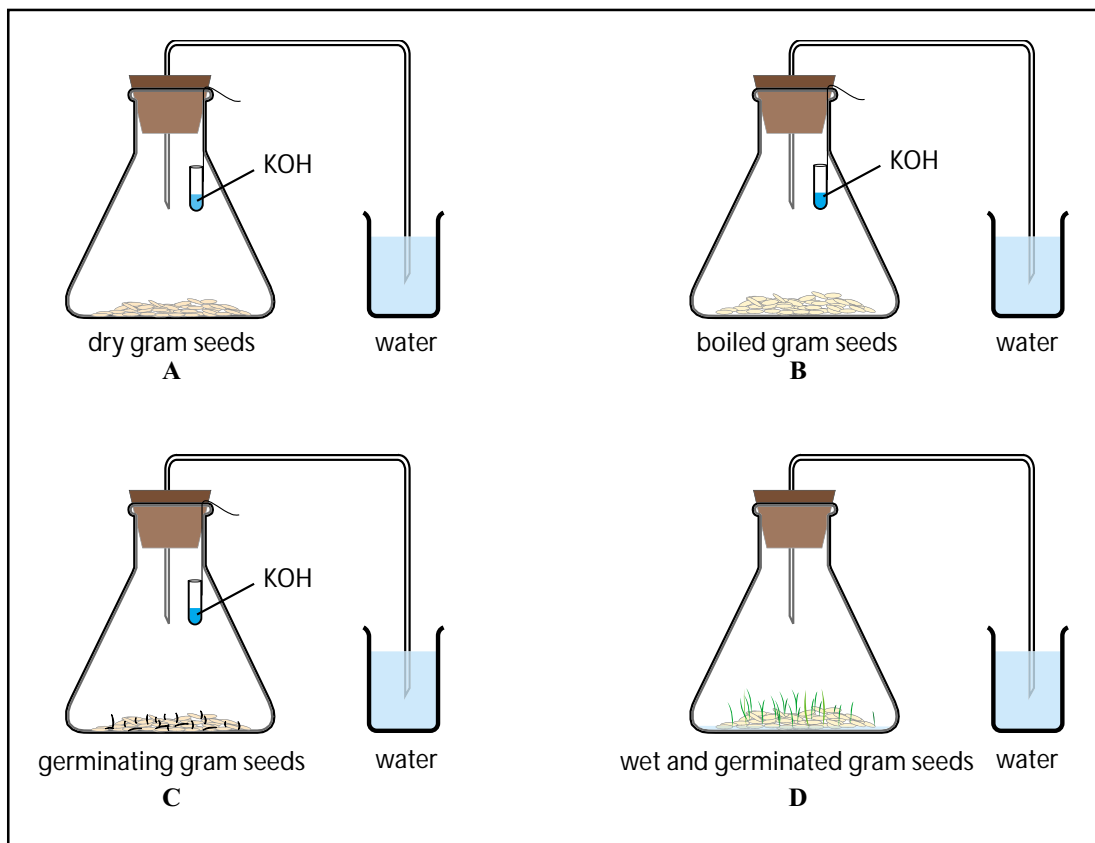

The set up that will give the desired result is

- (a) A.
- (b) B.
- (c) C.
- (d) D.

14. Students A, B and C were given five raisins each of equal weight. The raisins were soaked in distilled water at room temperature. A removed the raisins after 20 minutes, B after two hours and C after 40 minutes. If  $P_A$ ,  $P_B$  and  $P_C$  denote percentage absorption of water obtained by students A, B and C respectively, then

- (a)  $P_A > P_B > P_C$ .
- (b)  $P_A < P_B < P_C$ .
- (c)  $P_A < P_B > P_C$ .
- (d)  $P_A = P_B = P_C$ .

15. The budding in yeast is illustrated by the diagram

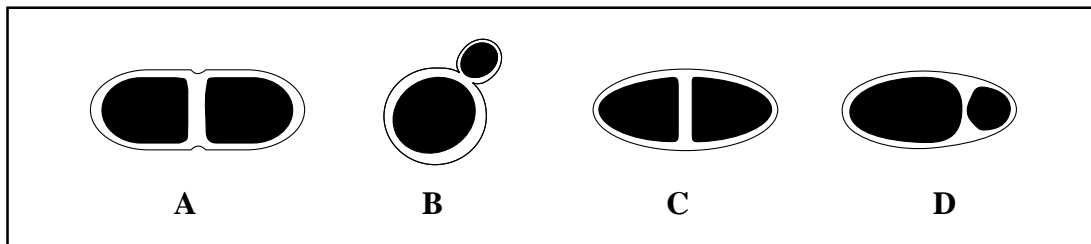

- (a) A.
- (b) B.
- (c) C.
- (d) D.

16. A student dissolved 1 g of sugar in 10 mL of distilled water in a beaker A. He dissolved 10 g of sugar in 100 mL of distilled water in beaker B. Then he dropped a few raisins, in each. After two hours he found the raisins

- (a) swollen in A and shrunken in B.
- (b) shrunken in A and swollen in B.
- (c) swollen in both.
- (d) shrunken in both.

17. 10 mL of freshly prepared iron sulphate was taken in each of four test tubes. Strips of copper, iron, zinc and aluminium were introduced, each metal in a different test tube. A black residue was obtained in two of them. The right pair of metals forming the precipitates is

- (a) copper and zinc.
- (b) aluminium and copper.
- (c) iron and aluminium.
- (d) zinc and aluminium.

18. The following symbols are usually shown on the bottles of commercial acetic acid.

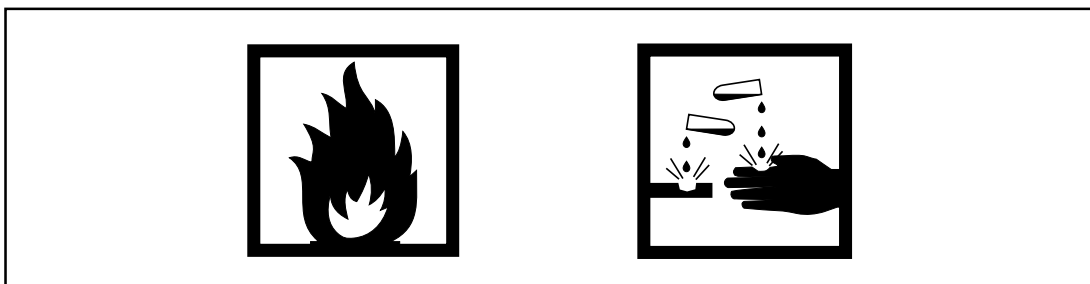

The symbols indicate that acetic acid is

- (a) corrosive and flammable.
- (b) radioactive and flammable.
- (c) oxidizing and corrosive.
- (d) flammable and explosive.

19. A strip of copper was placed in a beaker containing zinc sulphate solution. On observing the strip the next day, it was noticed that

- (a) the copper strip remained as it was.
- (b) the copper strip became thinner.
- (c) the copper strip became thicker.
- (d) the colour of the strip changed.

20. Amount of 5 mL each of acetic acid and water are mixed together and shaken well.

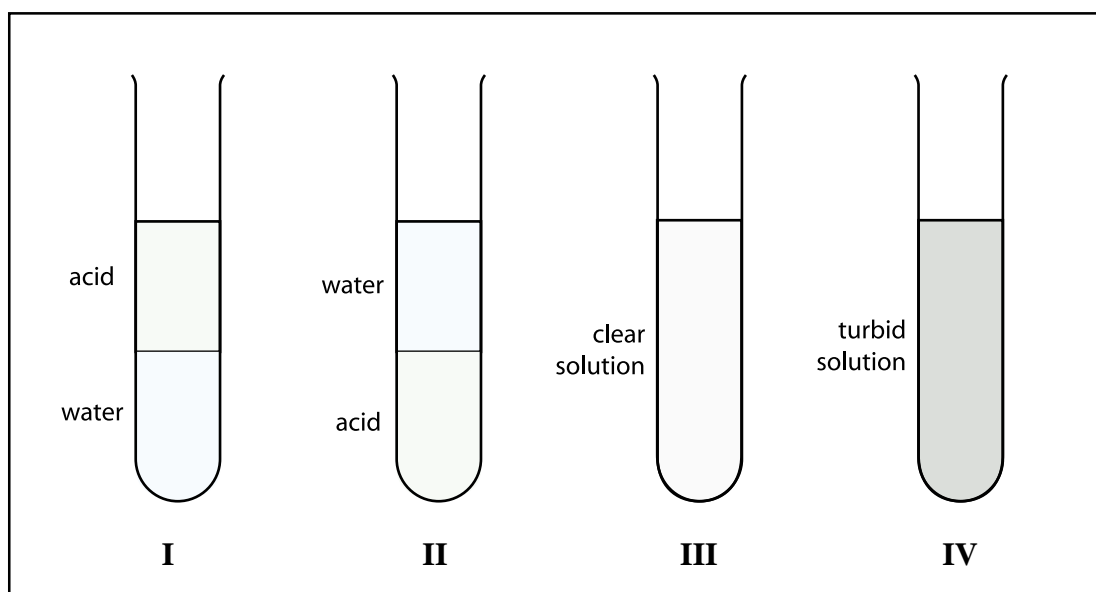

The resulting mixture would appear as in

- (a) I.
- (b) II.
- (c) III.
- (d) IV.

**SECTION - B**

21. Four students studied reactions of zinc and sodium carbonate with dilute hydrochloric acid and dilute sodium hydroxide solutions and presented their results as follows. The ✓ represents evolution of gas, whereas ✗ represents absence of any reaction.

	Zn	Na <sub>2</sub> CO <sub>3</sub>		Zn	Na <sub>2</sub> CO <sub>3</sub>
HCl			HCl		✗
NaOH		✗	NaOH		
	<b>A</b>			<b>B</b>	
	Zn	Na <sub>2</sub> CO <sub>3</sub>		Zn	Na <sub>2</sub> CO <sub>3</sub>
HCl	✗	✗	HCl		
NaOH			NaOH	✗	✗
	<b>C</b>			<b>D</b>	

The right set of observations is that of student

- (a) A.
- (b) B.
- (c) C.
- (d) D.

22. Out of the four set ups shown for carrying out the experiment to trace the path of a ray of light through a rectangular glass slab, the best set up is

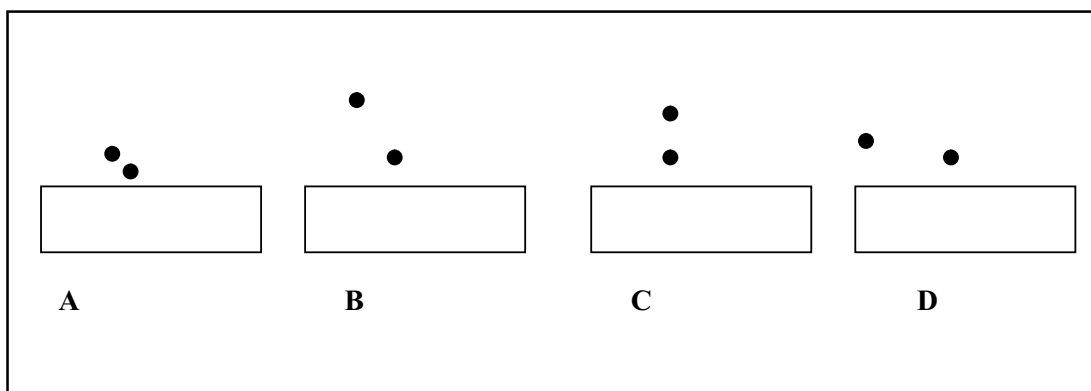

- (a) A.
- (b) B.
- (c) C.
- (d) D.

23. The resistors R1 and R2 are connected in

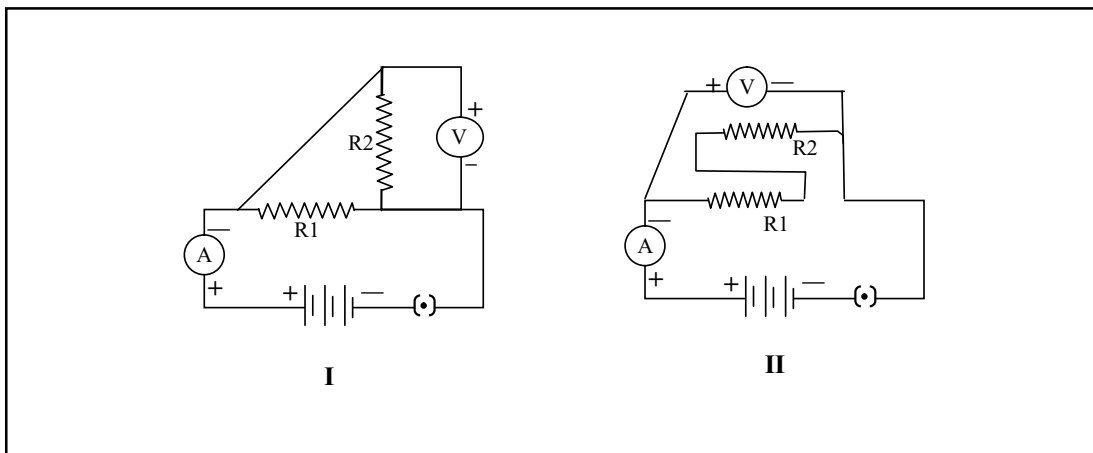

- (a) parallel in both circuits.
- (b) series in both circuits.
- (c) parallel in circuit I and in series in circuit II.
- (d) series in circuit I and in parallel in circuit II.

24. Circuit I: ammeter reads current  $i_1$  and voltmeter reads  $V_1$   
 Circuit II: ammeter reads current  $i_2$  and voltmeter reads  $V_2$

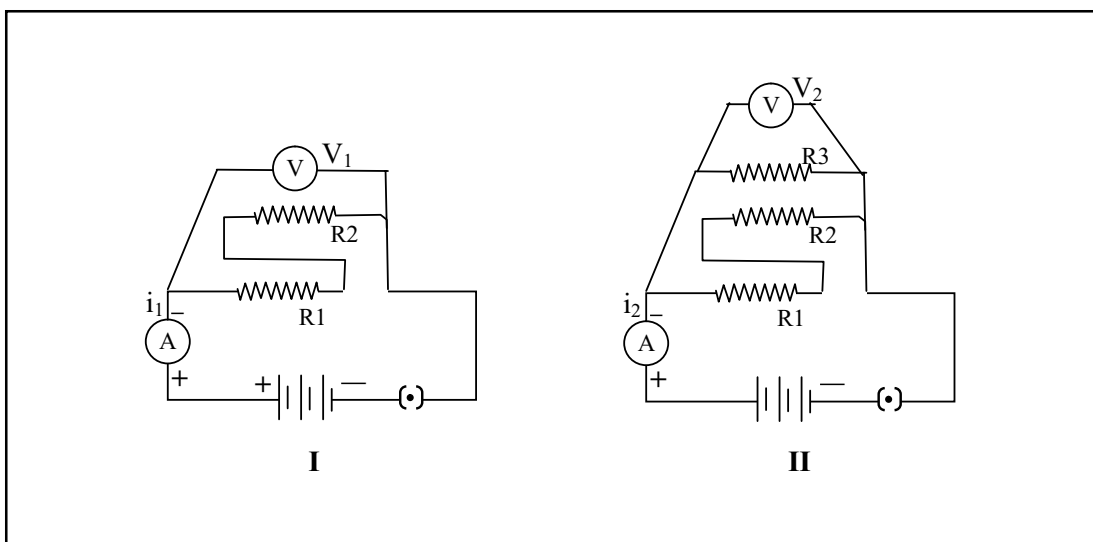

The relationship between the readings is

- (a)  $i_1 > i_2$ ;  $V_1 = V_2$ .
- (b)  $i_1 < i_2$ ;  $V_1 = V_2$ .
- (c)  $i_1 > i_2$ ;  $V_1 > V_2$ .
- (d)  $i_1 < i_2$ ;  $V_1 < V_2$ .

25. A student performed the starch test on a leaf. Some steps involved are shown below.

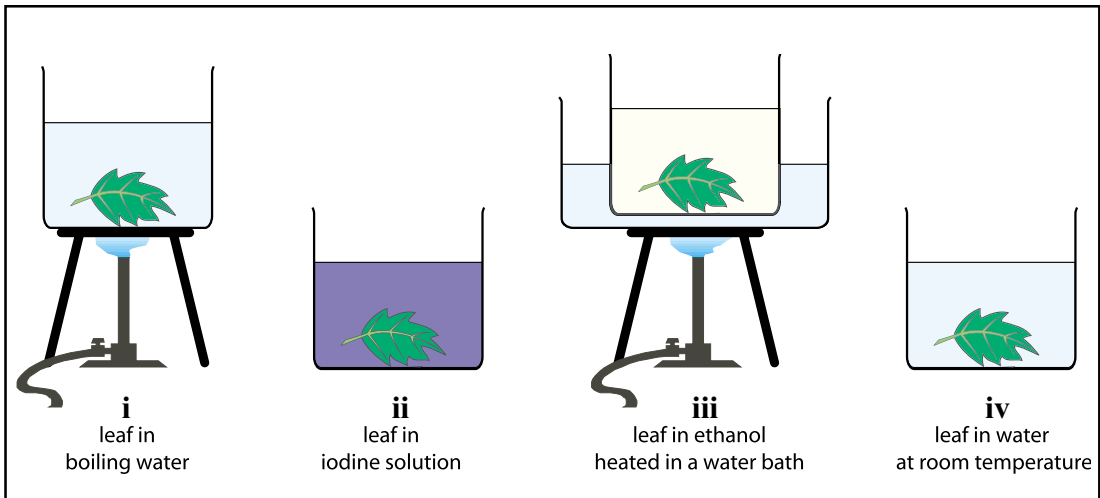

The correct sequence of steps should be

- (a) iv; iii; ii; i.
  - (b) i; ii; iii; iv.
  - (c) ii; iii; iv; i.
  - (d) i; iii; iv; ii.
26. A part of de-starched leaf of a potted plant was covered with black paper strips on both sides and the plant was kept in sunlight for 8 hours. The leaf was then tested with iodine after boiling it in alcohol. Only the uncovered part of the leaf turned blue black. The inference is that
- (a)  $\text{CO}_2$  is necessary for photosynthesis.
  - (b) light is necessary for photosynthesis.
  - (c) chlorophyll is necessary for photosynthesis.
  - (d) water is necessary for photosynthesis.

27. In the experiment shown in the figure, water is found to rise in the bent tube.

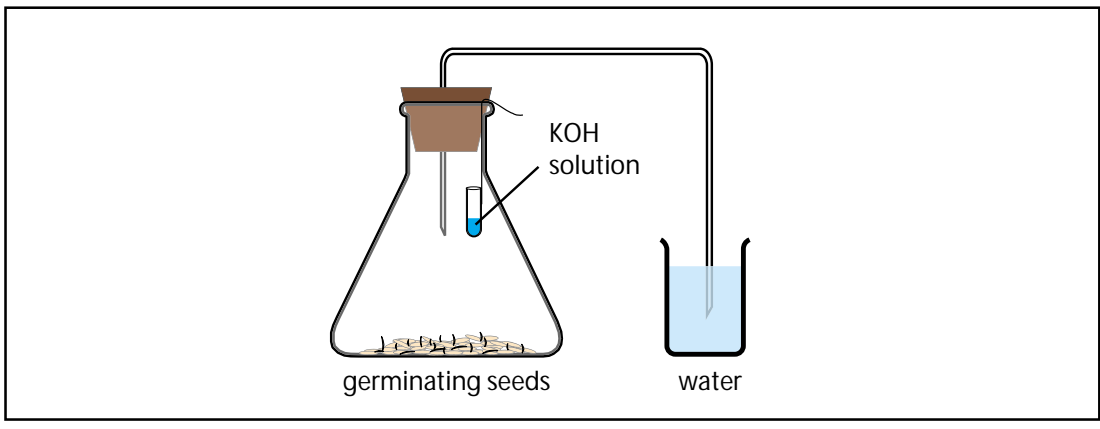



The reason is that

- (a) seeds use up oxygen in the flask.
- (b) carbon dioxide is given out by the germinating seeds.
- (c) germinating seeds attract water from the beaker.
- (d) seeds use oxygen and release carbon dioxide which is absorbed by potassium hydroxide.

28. A student is given a permanent slide showing binary fission in Amoeba. The following are the steps in focussing the object under the microscope.

- (i) Place the slide on the stage; look through the eye piece and adjust the mirror and diaphragm to get even illumination.
- (ii) Look through the eye piece and raise the objective using coarse adjustment until the object is focused.
- (iii) Make the focus sharp with the help of fine adjustment.
- (iv) Look through the eye piece and move the slide until the object is visible.

The proper sequence of steps is

- (a) (i), (iii), (iv), (ii).
- (b) (ii), (iii), (iv), (i).
- (c) (iv), (iii), (ii), (i).
- (d) (i), (iv), (ii), (iii).

29. For preparing sulphur dioxide in the laboratory the correct set up is shown in figure

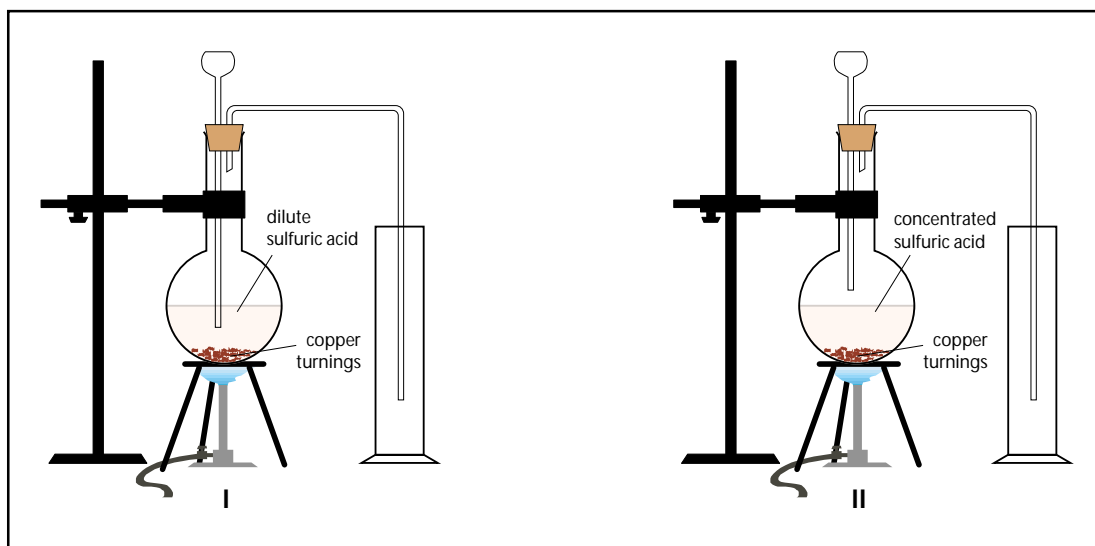

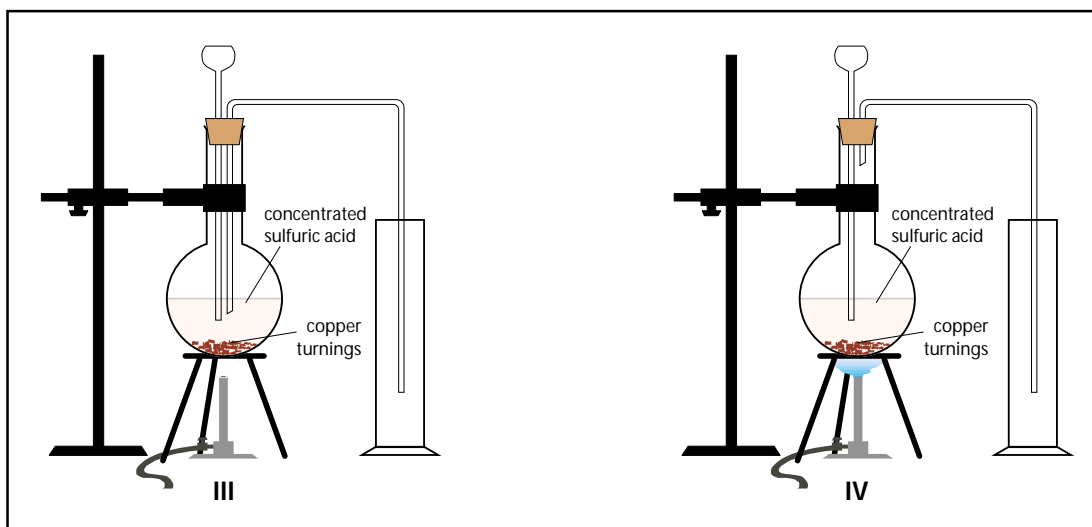

- (a) I.
- (b) II.
- (c) III.
- (d) IV.

30. A student added acetic acid to test tubes I, II, III and IV and then introduced a burning candle near the mouth of each test tube.

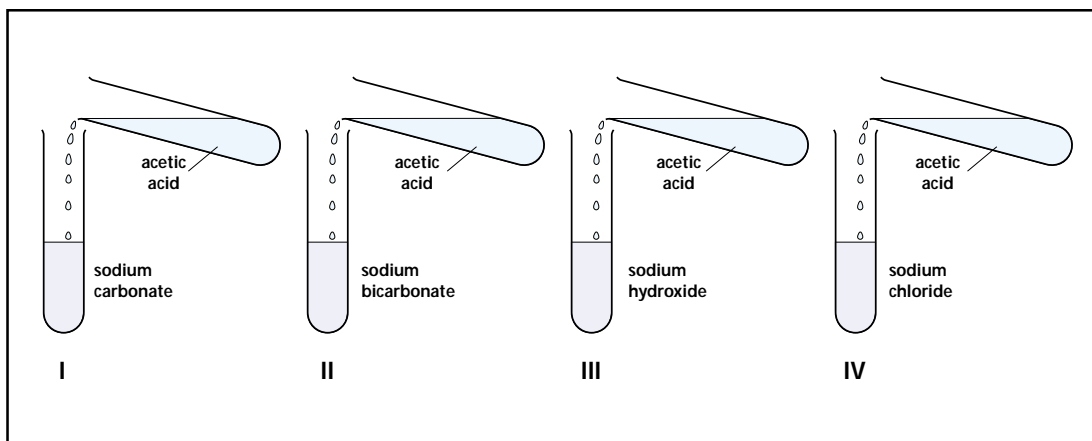

The candle would not be extinguished near the mouths of test tubes

- (a) I and II.
- (b) II and III.
- (c) III and IV.
- (d) I and IV.

## Question-wise Analysis and Scoring Key for Sample Paper I

Q.No	Expt. No.	Correct choice	Skills Tested	Explanation/ Remarks
1.	1	(a)	O	Red colour is at the top and blue colour is at the bottom.
2.	1	(a)	O, R	The colour of pH paper is green in neutral medium, whereas it is red in acidic medium.
3.	2	(b)	O	The surface becomes black and dull as the reaction proceeds.
4.	3	(a)	P,O	For the correct measurement of focal length, must have a sharp image on the screen and the meter scale must be correctly positioned between the (sharp image) screen and the centre of the concave mirror.
5.	3	(c)	O	The image gets blurred and enlarged/shortened when the screen is pushed farther/nearer from the focus of the convex lens.
6.	4	(a)	P,M	We need to keep the eye far from the glass slab to have a good and proper alignment of the pins.
7.	5	(b)	P,O	We must not only put the ammeter in series and the voltmeter in parallel (with the resistor) but also ensure that the polarities of both the instruments are correct.
8.	5	(a)	D, I	The plotted points should not only lie (nearly) on a straight line but the straight line must also pass through the origin. Also the current should increase (proportionally) with the applied potential difference.
9.	5,(6,7)	(d)	D, I	Circuit (I), with no dot put in between the plug key symbol, is an open circuit. Circuit (II), with the dot put there, is a closed circuit in which a current of 5/5 A i.e. 1 A would flow.
10.	5,(6,7)	(c)	P, I	We would have a current flowing in the ammeter but no deflection in the voltmeter only if the voltmeter connections are loose.
11.	8	(b)	O, D	Guard cells have nucleus as well as chloroplasts.
12.	9	(d)	O, I	Covered portion of the leaf does not get sunlight irrespective of the colour of the strip.
13.	10	(c)	O, R	In (a) seeds are dormant, in (b) killed by cooking and in (d) there is no KOH.
14.	12	(c)	P, O, R	Absorption of water increases with time up to its maximum limit.
15.	11	(b)	O	The bud in yeast appears as a protuberance.
16.	12	(c)	P, O, R	Solutions in both A and B are hypotonic to raisins and hence they swell.
17.	14	(d)	O, R, I	Zinc and aluminium being more reactive will replace iron from iron sulphate.
18.	15	(a)	M, O	Acetic acid is corrosive and flammable.
19.	14	(a)	O, R	Copper is less reactive than zinc and, therefore, no reaction occurs.
20.	15	(c)	O	Acetic acid is miscible with water forming a clear solution.
21.	2	(a)	O, R	Zinc reacts with dilute HCl and NaOH, whereas $\text{Na}_2\text{CO}_3$ reacts only with dilute HCl.

22.	4	(b)	P, O	We must not only ensure that the two pins (on the incident ray) are relatively far apart but also keep the angle of incidence preferably between $30^{\circ}$ and $60^{\circ}$ .
23.	6,7	(c)	O, I	We must not look for a stereotyped circuit diagram but look for the basic condition for (i) parallel (ii) series connection of two resistors in a given circuit.
24.	6,7	(b)	O, I	The equivalent resistance, of a parallel combination of resistors, is less than the resistance of either of its two branches. The equivalent resistance, in circuit 2, is, therefore, less than $(R_1+R_2)$ (the equivalent resistance of circuit 1) and hence the current flowing through it increases. The voltage reading, in both cases, is, however, the same.
25.	9	(d)	P, O	Boiling kills the cells, chlorophyll leaches out when boiled in ethanol, but the leaf becomes brittle, made normal by washing it in water. Starch gets stained with iodine.
26.	9	(b)	P, O, R	Black paper covering prevents light.
27.	10	(d)	O, R, I	Seeds release $\text{CO}_2$ during respiration, which is absorbed by KOH creating a partial vacuum in the flask. To fill that water rises.
28.	11	(d)	P, M, O	Proper sequence is to be followed to handle the microscope and to focus the specimen.
29.	13	(d)	M, P, D	Copper reacts with concentrated $\text{H}_2\text{SO}_4$ on heating to give $\text{SO}_2$ . The tip of the thistle funnel should dip into conc. $\text{H}_2\text{SO}_4$ .
30.	15	(a)	P, O, D	Acetic acid reacts with $\text{Na}_2\text{CO}_3$ and $\text{NaHCO}_3$ to liberate $\text{CO}_2$

## Sample Question Paper II

Time: 1 ½ hours

Maximum Marks: 20

### INSTRUCTIONS

1. Attempt all questions
2. There are 30 multiple choice questions in total. Only one of the options in every question is correct.
3. The question paper consists of two parts – Section A and Section B. Each of the 20 questions in Section A carries 0.5 mark and each of the 10 questions in Section B carries 1.0 mark.

### SECTION - A

1. A student tested the pH of distilled water and found that the colour of the pH paper changed to green. He checked the pH again after dissolving a pinch of common salt in it. The colour of the pH paper this time was
  - (a) green.
  - (b) yellow.
  - (c) red.
  - (d) blue.
  
2. Bottle A contains oxalic acid and bottle B contains sodium carbonate solution. When pH paper is dipped in each of the solutions, the colour seen in A and B respectively be
  - (a) orange, blue.
  - (b) blue, orange.
  - (c) green, blue.
  - (d) orange, green.
  
3. The zinc metal used in the laboratory for doing experiments is available in the form of
  - (a) filings.
  - (b) strips.
  - (c) granules.
  - (d) pellets.

4. Parallel rays from a distant tree incident on a convex lens form an image on the screen.

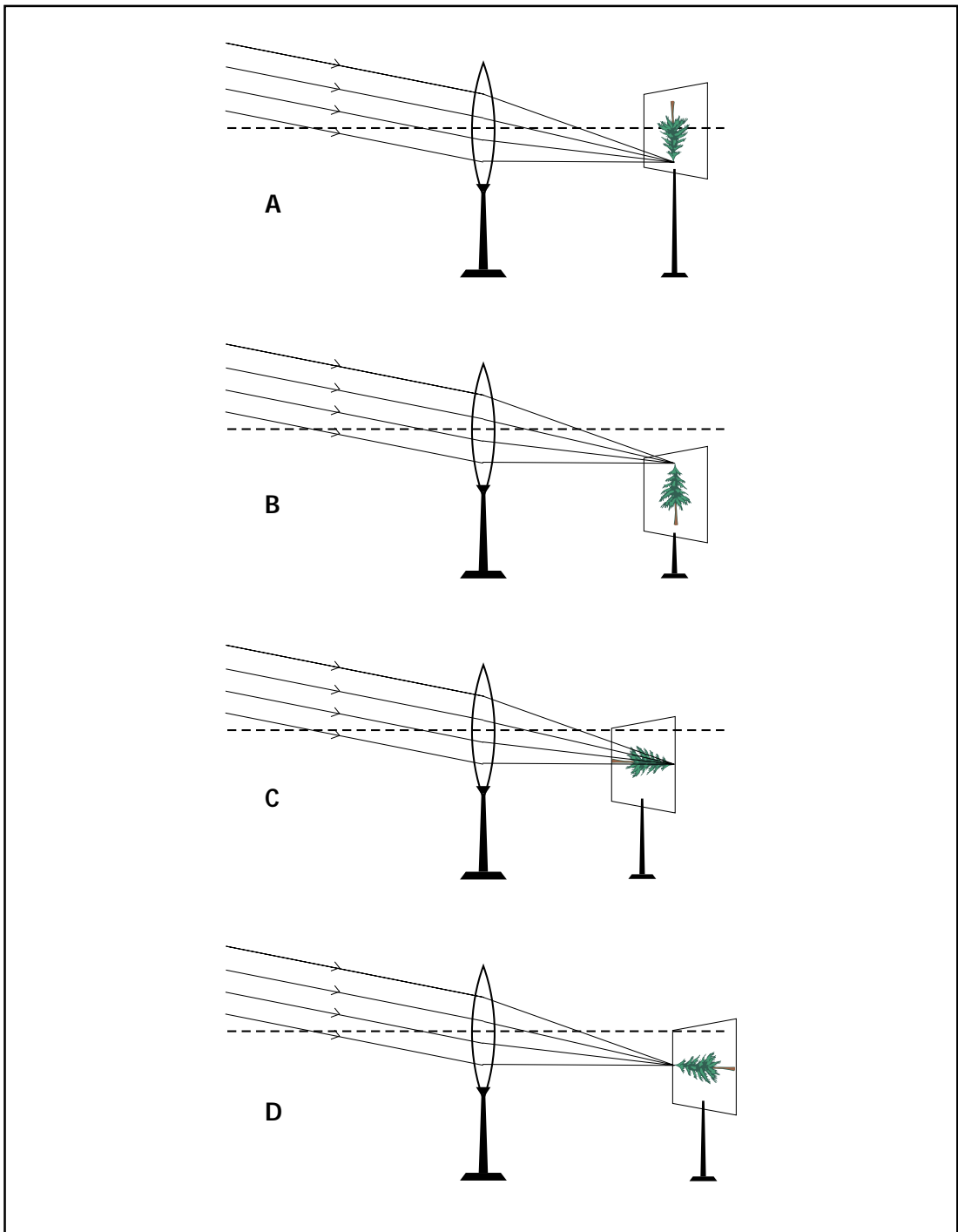

The diagram correctly showing the image of the tree on the screen is

- (a) A.
- (b) B.
- (c) C.
- (d) D.

5. In an experiment, the image of a distant object formed by a concave mirror is obtained on a screen. To determine the focal length of the mirror, you need to measure the distance between the
- mirror and the screen.
  - mirror and the object.
  - object and the screen.
  - mirror and the screen and also between the object and the screen.
6. In the experiment to trace the path of a ray of light through a rectangular glass slab using pins P1, P2, P3 and P4, four students did the following  
 A looked at heads of P1 and P2 while placing P3, and heads of P1, P2 and P3 while placing P4  
 B: looked at feet of P1 and P2 while placing P3, and feet of P1, P2 and P3 while placing P4  
 C: looked at heads of P1 and P2 while placing P3, and feet of all the pins while placing P4  
 D: looked at feet of P1 and P2 while placing P3, and heads of all the pins while placing P4  
 The correct procedure is that of student
- A.
  - B.
  - C.
  - D.
7. The normal positions of the pointers of the two ammeters  $A_1$  and  $A_2$ , and two voltmeters  $V_1$  and  $V_2$  available in the laboratory were as shown. For an experiment to study the dependence of the current on the potential difference across a resistor, the student should select
- ammeter  $A_1$  and voltmeter  $V_1$ .
  - ammeter  $A_2$  and voltmeter  $V_1$ .
  - ammeter  $A_1$  and voltmeter  $V_2$ .
  - ammeter  $A_2$  and voltmeter  $V_2$ .

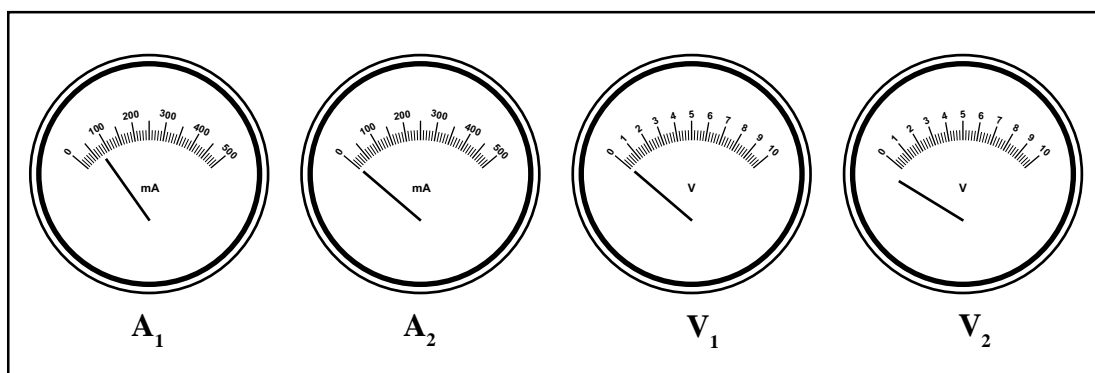

8. A student has to connect 4 cells of 1.5 V each, to form a battery of voltage 6 V.

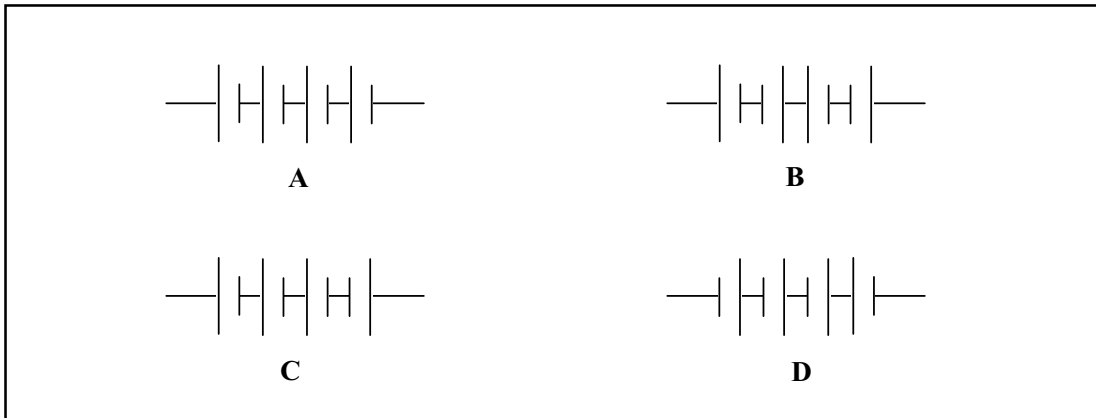

The correct way of connecting these cells is shown in figure

- (a) A.
- (b) B.
- (c) C.
- (d) D.

9. The correct way of connecting the ammeter and voltmeter with a series combination of two resistors in a circuit for finding their equivalent resistance, is shown in diagram

- (a) 1.
- (b) 2.
- (c) 3.
- (d) 4.

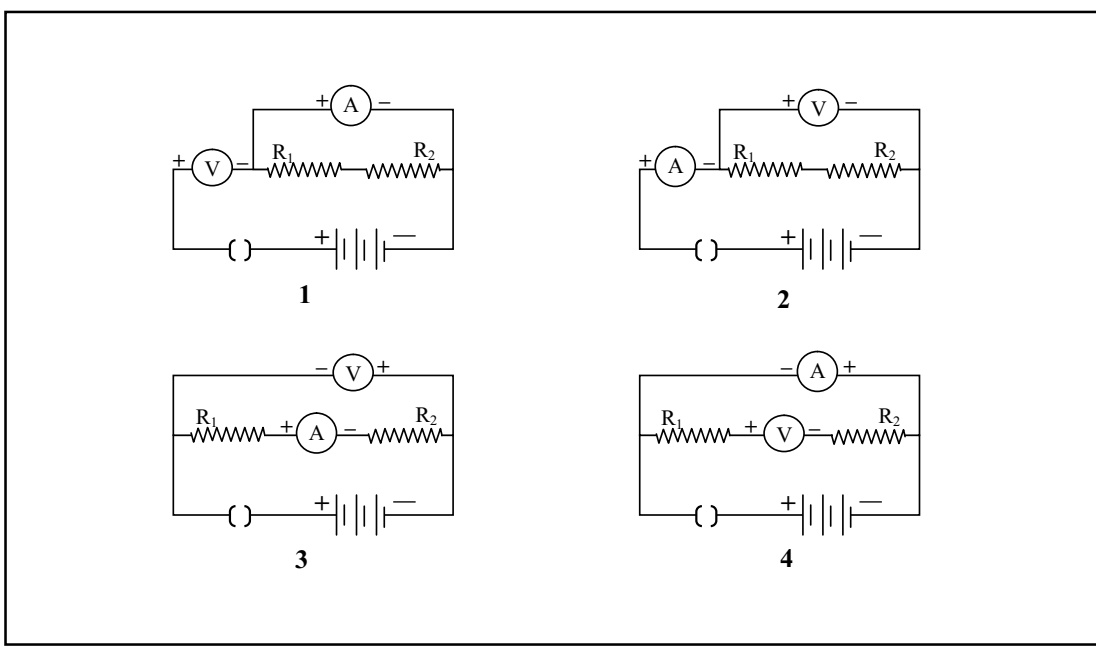



10. On plugging the key, the voltmeter/ ammeter is likely to be damaged in the circuit shown in figure

- (a) 1.
- (b) 2.
- (c) 3.
- (d) 4.

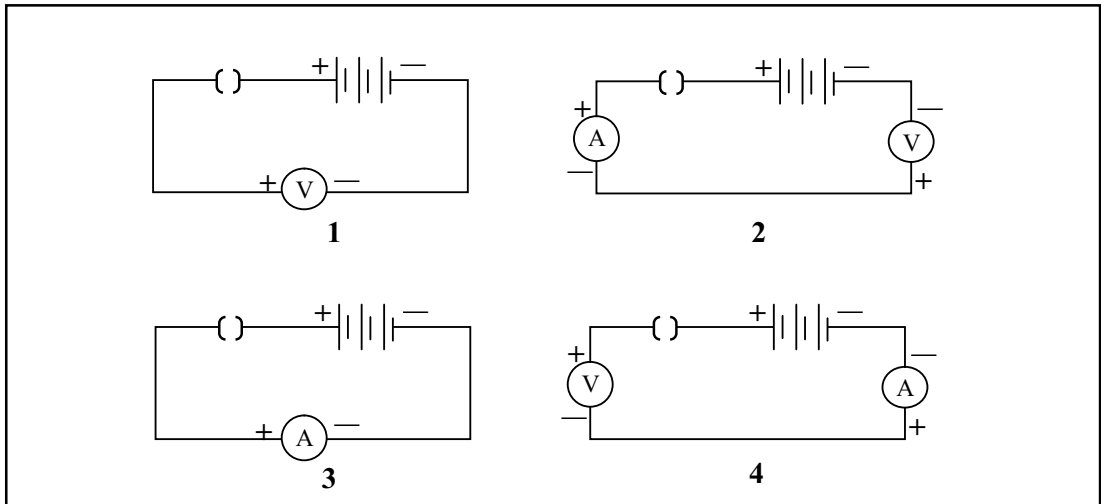

11. A student draws the following sketch of stomatal apparatus and numbers the parts to label them.

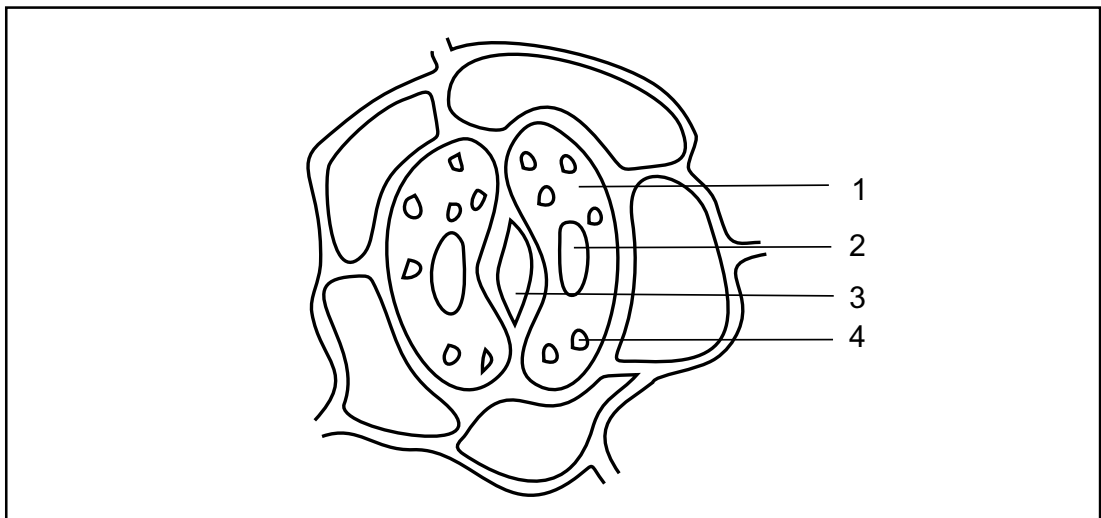

The chloroplast is denoted by

- (a) 1.
- (b) 2.
- (c) 3.
- (d) 4.

12. The following figures illustrate binary fission in Amoeba in an incorrect sequence.

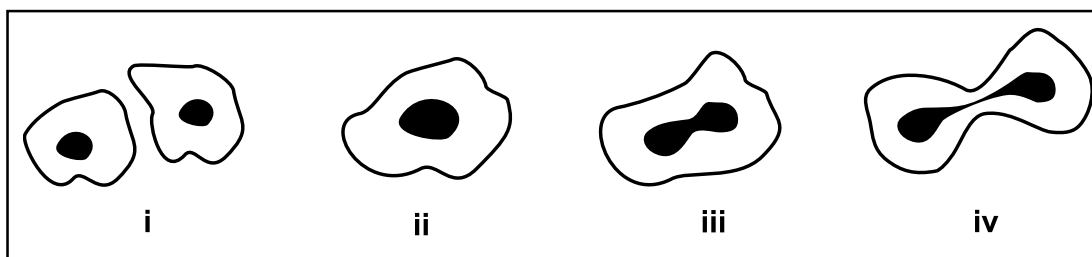

The correct sequence is

- (a) (i), (iii), (iv), (ii).
  - (b) (ii), (iii), (iv), (i).
  - (c) (iv), (iii), (ii), (i).
  - (d) (iii), (iv), (ii), (i).
13. The teacher instructed a student to place a healthy potted shoe flower plant in a dark room for 24 hours prior to an experiment on photosynthesis. The purpose of placing it in a dark room is
- (a) to increase the intake of  $\text{CO}_2$ .
  - (b) to activate the chloroplasts in the leaves.
  - (c) to de-starch the leaves.
  - (d) to denature the enzymes in the leaves.
14. In an experiment to show that sunlight is necessary for photosynthesis, the leaf is boiled in alcohol for a few minutes using a water bath. It is essential because
- (a) alcohol is highly volatile.
  - (b) steam from the water bath heats the leaf rapidly.
  - (c) steam from the water bath dissolves the chlorophyll.
  - (d) alcohol is flammable.
15. A student soaked 10 g of raisins in 50 mL of distilled water in two beakers A and B each. She maintained beaker A at 25 °C and beaker B at 50 °C. After an hour, the percentage of water absorbed will be
- (a) the same in both A and B.
  - (b) more in A than in B.
  - (c) more in B than in A.
  - (d) exactly twice as much in B as in A.

16. The following are the sketches made by some students.

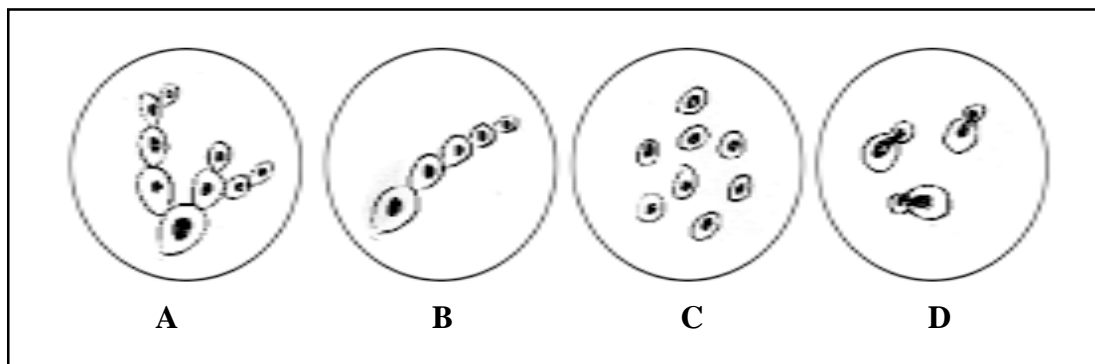

The sketch not illustrative of budding in yeast is

- (a) A.
- (b) B.
- (c) C.
- (d) D.

17. The pair of safety symbols you notice on the bottles of commercial acetic acid available in the laboratory, is shown in

- (a) I.
- (b) II.
- (c) III.
- (d) IV.

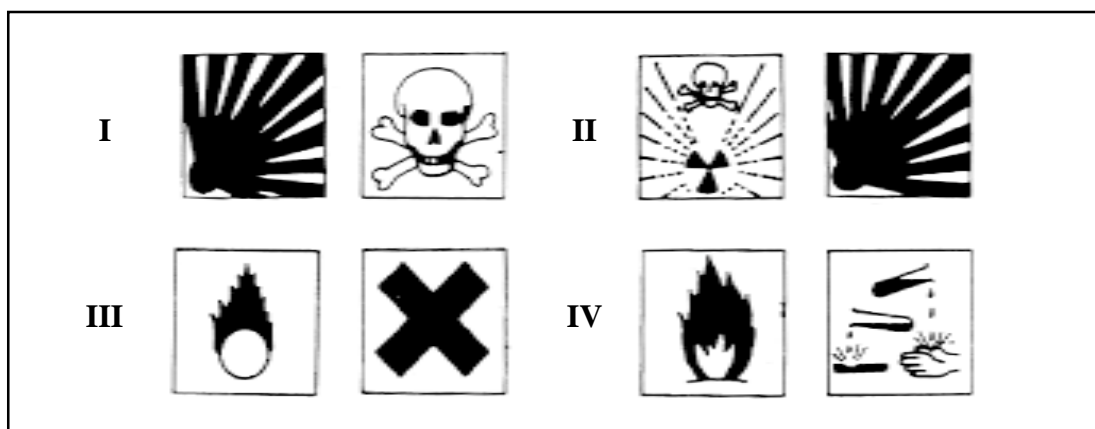

18. When you place an iron nail in copper sulphate solution, the reddish brown coating formed on the nail is

- (a) soft and dull.
- (b) hard and flaky.
- (c) smooth and shining.
- (d) rough and granular.

19. When you place an iron strip in the solution of copper sulphate, the time required for the colour of the solution to change from blue to green is about

- (a) a second.
- (b) an hour.
- (c) 8 hours.
- (d) 24 hours.

20. On adding sodium bicarbonate to acetic acid, you immediately

- (a) observe strong effervescence.
- (b) hear hissing sound.
- (c) get pungent smell.
- (d) notice formation of bubbles.

## SECTION - B

21. Four experimental set ups are shown below.

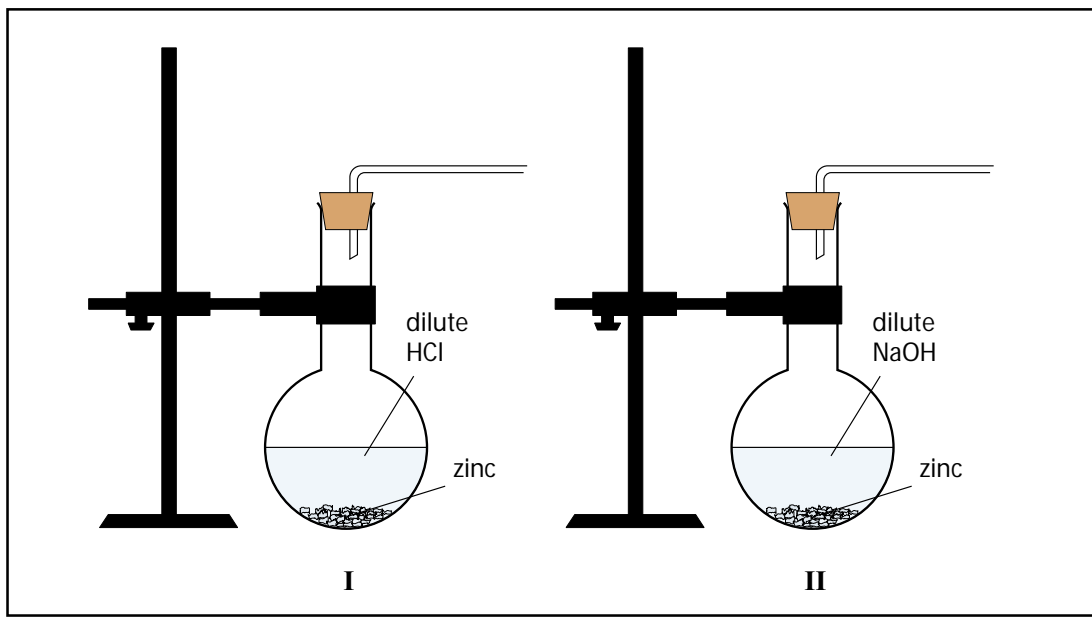

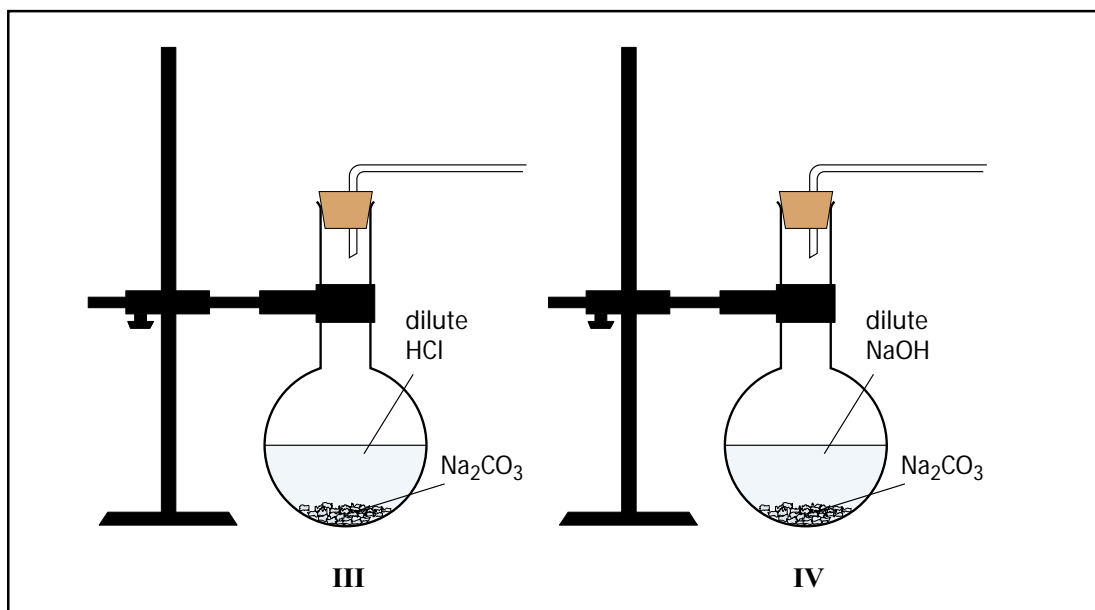

The set ups that would result in a rapid evolution of gas would be

- (a) I and III.
- (b) II and IV.
- (c) I and II.
- (d) III and IV.

22. Four students showed the following traces of the path of a ray of light passing through a rectangular glass slab.

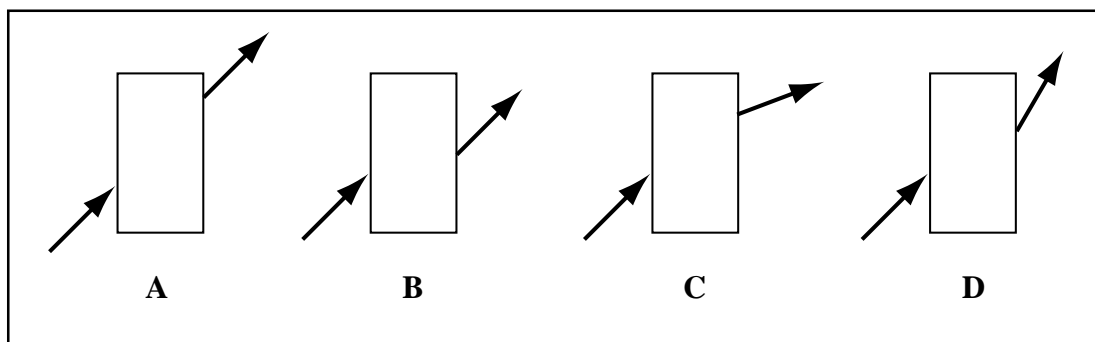

The trace most likely to be correct is that of student

- (a) A.
- (b) B.
- (c) C.
- (d) D.

23. The voltmeter, ammeter and resistance in the circuit shown have been checked and found to be correct. On plugging the key, the voltmeter reads 4.5 V, but the ammeter reads 1.5 A.

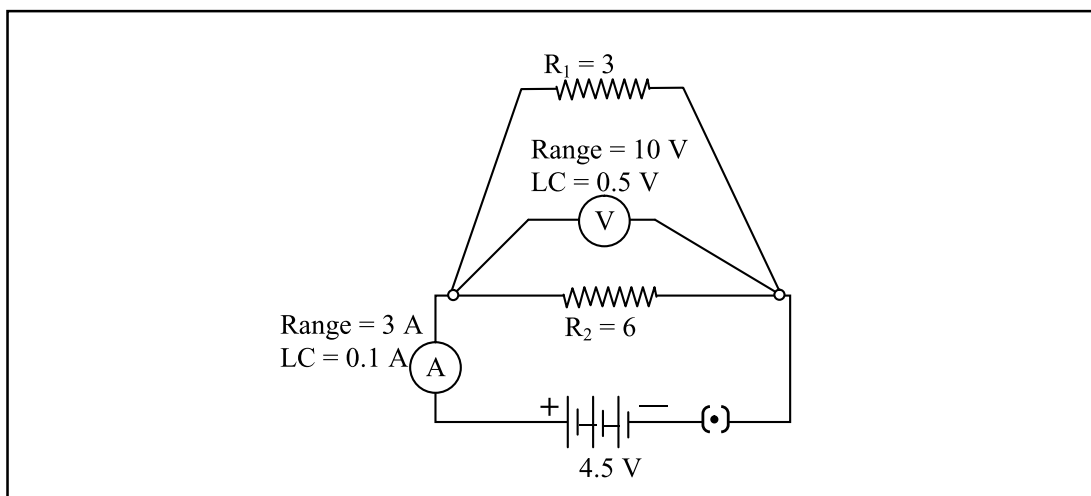

This could most likely be because the wires joined to

- (a) the resistor  $R_1$  are loose.
- (b) the resistor  $R_2$  are loose.
- (c) both the resistors  $R_1$  and  $R_2$  are loose.
- (d) the ammeter terminals are loose.

24. The following apparatus is available in a laboratory:

Battery : adjustable from 0 to 4.5 Volt

Resistors :  $3 \Omega$  and  $6 \Omega$

Ammeters : A1 of Range 0 to 3 A; Least Count 0.1 A

A2 of Range 0 to 1 A; Least Count 0.05 A

Voltmeters : V1 of Range 0 to 10 V; Least Count 0.5 V

V2 of Range 0 to 5 V; Least Count 0.1 V

The best combination of voltmeter and ammeter for finding the equivalent resistance of the resistors in series would be

- (a) ammeter A1 and voltmeter V1.
- (b) ammeter A1 and voltmeter V2.
- (c) ammeter A2 and voltmeter V1.
- (d) ammeter A2 and voltmeter V2.

25. In an experiment on photosynthesis, a student fixed a strip of black paper on the dorsal surface of a Bougainvillea leaf in the morning. In the evening she tested the leaf for starch. The result was

- (a) the dorsal surface of the leaf was white but the ventral surface turned blue.
- (b) both the surfaces of the covered portion remained white.
- (c) the entire leaf turned blue black.
- (d) the entire leaf remained white.

26. Given below are the steps in the preparation of a temporary mount of a stained leaf peel.

- (i) Cover the material with the cover slip.
- (ii) Transfer the stained peel to the clean glass slide and add a drop of glycerine.
- (iii) Remove the peel from the ventral surface of the leaf.
- (iv) Drop it in the water in a petri dish and add a drop of safranin stain.

The correct sequence of steps is

- (a) (iii), (iv), (ii), (i).
- (b) (i), (ii), (iii), (iv).
- (c) (ii), (iii), (iv), (i).
- (d) (iii), (iv), (i), (ii).

27. After performing the experiment to show that germinating seeds give out carbon dioxide during respiration, students drew the following diagrams.

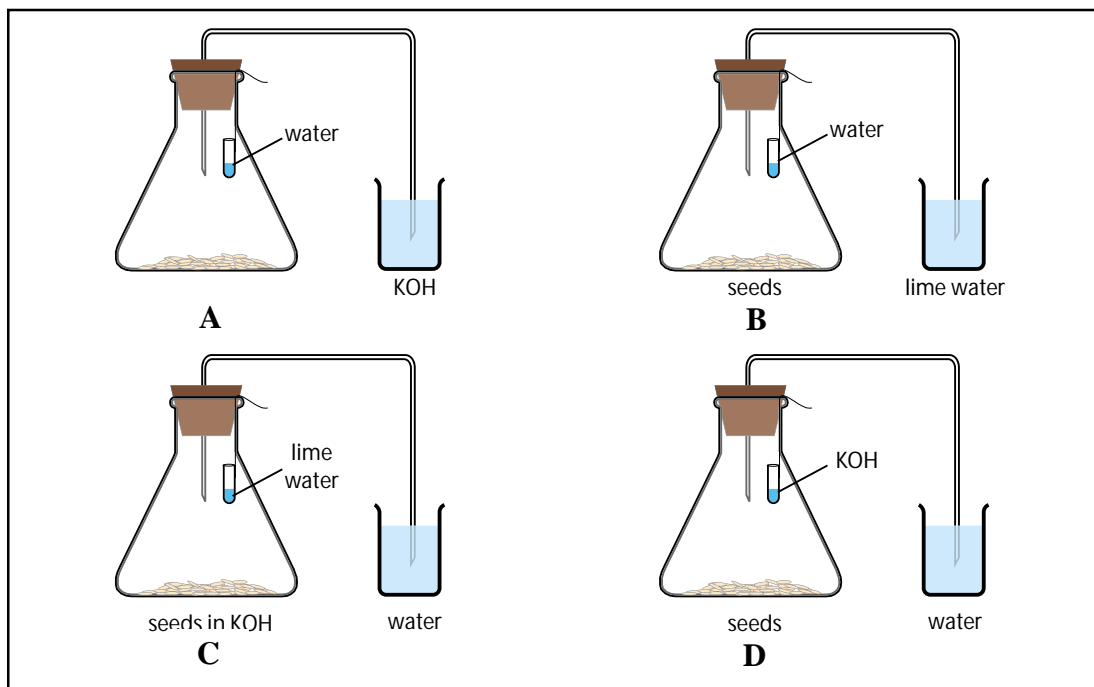

The correct labelled diagram is

- (a) A.
- (b) B.
- (c) C.
- (d) D.

28. A student sets up the apparatus for the experiment to show that  $\text{CO}_2$  is released during respiration. After 2 hours, he would observe

- (a) KOH turning milky.
- (b) water level rising in the bent tube in the beaker.
- (c) water level decreasing in the bent tube in the beaker.
- (d) water turning turbid in the beaker.

29. Zinc granules were added to zinc sulphate, copper sulphate, aluminum sulphate and iron sulphate solutions as shown below. You would observe the deposition of metal on zinc in beakers

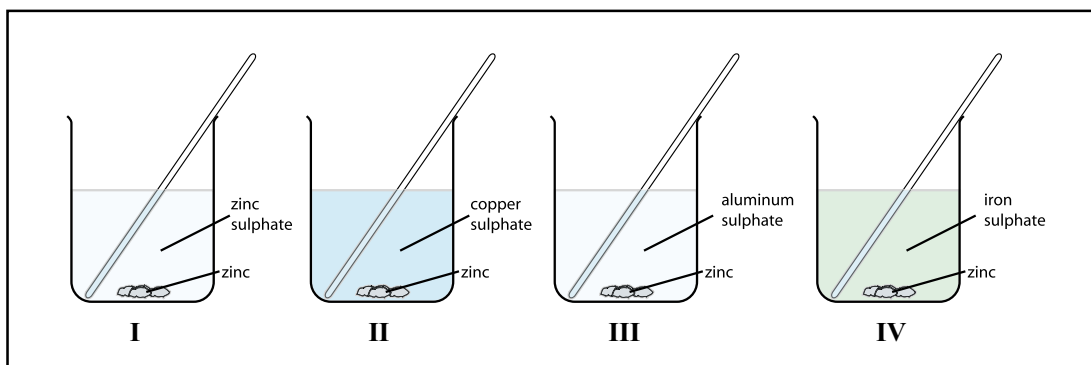

- (a) I and III.
- (b) II and IV .
- (c) I and II.
- (d) III and IV.

30. Among the four sets of apparatus given below, the correct one to prepare sulphur dioxide gas is

Set I	Set II	Set III	Set IV
Hard glass test tubes 2, double holed rubber cork 1, thistle funnel 1, delivery tube 1, spirit lamp 1	Round bottomed flask 1, gas jar 1, double holed rubber cork 1, thistle funnel 1, delivery tube 1, spirit lamp 1	Conical flask 2, delivery tube 1, thistle funnel 1, single holed rubber cork 2, spirit lamp 1	Conical flask 1, beaker 1, funnel 1, delivery tube 1, double holed rubber cork 1, spirit lamp 1

- (a) Set I
- (b) Set II
- (c) Set III
- (d) Set IV



## Question-wise Analysis and Scoring Key for Sample Paper II

Q.No	Expt. No.	Correct choice	Skills Tested	Explanation/ Remarks
1.	1	(a)	O	The pH paper in neutral medium gives green colour.
2.	1	(a)	O, I	The colour of pH paper is orange in acidic medium while it is blue in basic medium.
3.	2	(c)	O	Zinc is available in the form of granules in the laboratory.
4.	3	(b)	O	The image of the (vertical) tree on the screen will be an inverted vertical image.
5.	3	(a)	P, I	The focal length of the lens equals the distance between the lens and the (sharp) image obtained on the screen.
6.	4	(b)	P	It is difficult to fix the pins vertically and we can have a proper alignment of the feet of the pins.
7.	5	(b)	P	We should select instruments without any zero error.
8.	5,6,7	(a)	P	The four cells must be connected in series to get a total voltage of $4 \times 1.5 = 6.0V$ . For this, the negative of the first cell must be connected to the positive of the second cell, and so on, leaving the positive of the first cell and negative of the fourth cell to be connected to the circuit.
9.	6	(b)	P/M	The ammeter must be connected in series, between the battery and the series combination of the two resistors, and the voltmeter should be put in parallel across the series combination of the two resistors. All the polarities must also be correct.
10.	5,6,7	(c)	I	The ammeter, being a very low resistance device, would draw a very large current when connected directly to the battery. This burns out/ damages its coil.
11.	8	(d)	O, D	No. 4 is chloroplast.
12.	11	(b)	O, D	Nucleus divides first and then the cytoplasm, when Amoeba undergoes fission.
13.	9	(c)	P, O, R	24 hours to shunt starch from the leaves to the rest of the plant. De-starched leaf will show the colour change.
14.	9	(d)	P	Water bath is a must to boil the leaf in ethanol as a precaution.
15.	12	(c)	O, R	Absorption is facilitated in warm water.
16.	11	(c)	O, D	Buds appear as protuberances.
17.	15	(d)	P, O	Acetic acid is flammable and corrosive.
18.	14	(a)	O	The freshly deposited copper is soft and dull.
19.	14	(b)	O, P	Metal deposition is not very fast and takes some time.
20.	15	(a)	O	The reaction between acetic acid and sodium bicarbonate to produce carbon dioxide is very fast.
21.	2	(a)	P, D	The reactions between (i) Zinc and dil. HCl and (ii) dil. HCl and $Na_2CO_3$ are fast whereas the reaction between Zn and NaOH is slow.

22.	4	(b)	O, D	The emergent ray, from the rectangular glass slab, is parallel to the incident ray and is laterally displaced to the left (or lower side) of the incident ray.
23.	7	(b)	O, I	The ammeter reading being $1.5\text{ A} (=4.5\text{V}/3)$ , only the three ohm resistor is connected to the circuit while the other six ohm resistor, because of its loose connection, is not part of the circuit at all.
24.	6	(d)	O, I	The overall range of the voltage is from 0 to 4.5V and that of current is from 0 to $4.5/9\text{ A} = 0.5\text{ A}$ . We, therefore, prefer instruments that cover these ranges and also have a better least count.
25.	9	(c)	O, R	In the diffused light reaching the ventral surface, photosynthesis takes place, and so the whole leaf responds to starch test.
26.	8	(a)	P	The sequence is important to get the best stained material for the temporary mount.
27.	10	(d)	P, O	Proper labelling of KOH in the suspended test tube, water in the beaker and seeds in the conical flask.
28.	10	(b)	O, R	CO <sub>2</sub> released is absorbed by KOH. To fill the partial vacuum created in the conical flask, water rises in the bent tube.
29.	14	(b)	O, I	Zinc displaces iron and copper from their salt solutions.
30.	13	(b)	P, M	The apparatus required for the preparation and collection of SO <sub>2</sub> is given in Set II only.

## Sample Question Paper III

Time: 1 ½ hours

Maximum Marks: 20

### INSTRUCTIONS

1. Attempt all questions
2. There are 30 multiple choice questions in total. Only one of the options in every question is correct.
3. The question paper consists of two parts – Section A and Section B. Each of the 20 questions in Section A carries 0.5 mark and each of the 10 questions in Section B carries 1.0 mark.

### SECTION A

1. A student took the following samples to find out their pH using pH paper. The teacher remarked that one of the samples taken was not proper. The teacher was referring to
  - (a) dilute hydrochloric acid.
  - (b) lemon juice.
  - (c) washing soda.
  - (d) soap solution.
2. To test the presence of an acid with a strip of red litmus paper you would
  - (a) dip the strip as it is in the sample and see the colour change.
  - (b) moisten the paper with water and dip in the given sample.
  - (c) first dip strip in common salt solution and then use to it test the sample.
  - (d) first dip strip in alkaline solution and then use it to test the sample.
3. The figures below show set-ups for studying the reaction of zinc with sodium hydroxide.

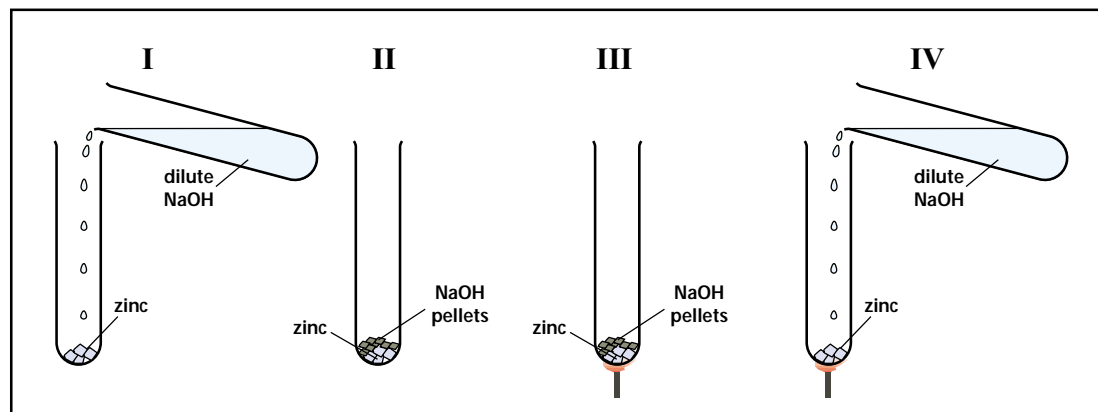

A rapid evolution of hydrogen gas will be observed in the test tube

- (a) I.
- (b) II.
- (c) III.
- (d) IV.

4. Parallel rays, from the top of a distant tree, incident on a concave mirror, form an image on the screen.

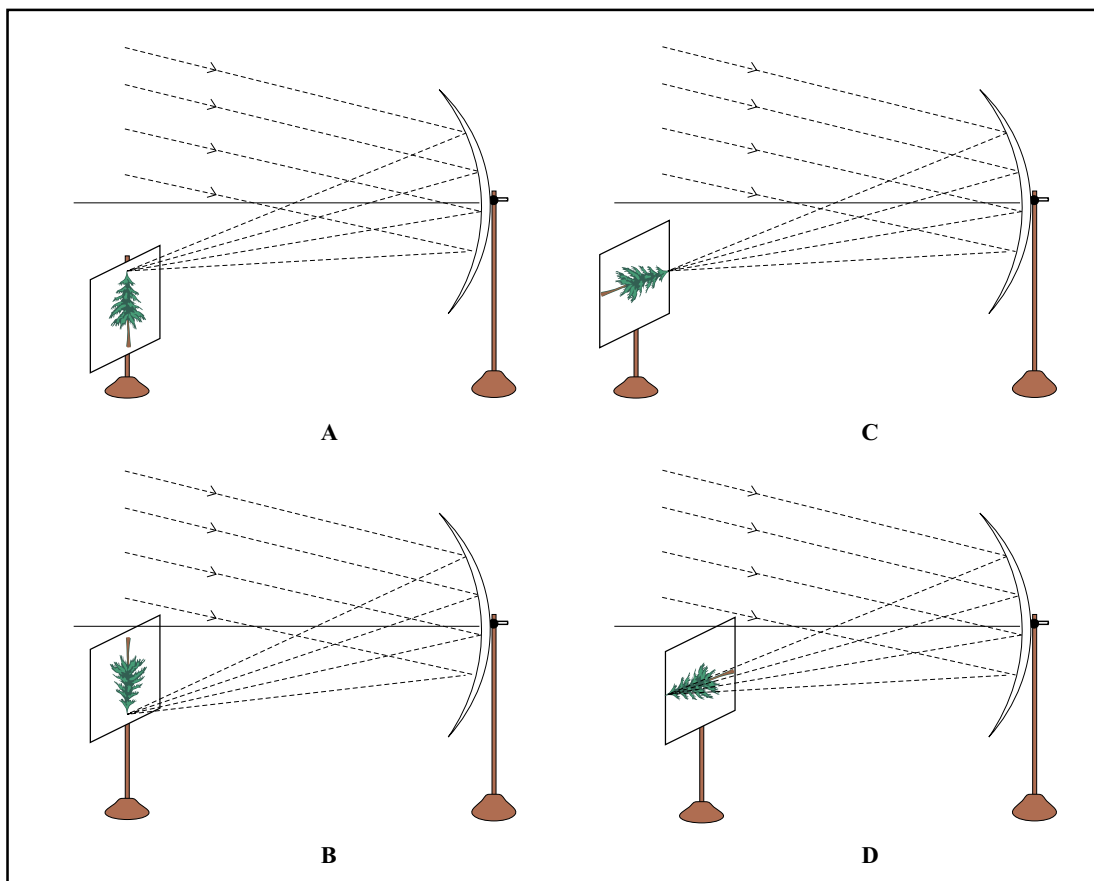

The diagram correctly showing the image of the tree on the screen is

- (a) A.
- (b) B.
- (c) C.
- (d) D.

5. In an experiment to trace the path of a ray of light passing through a rectangular glass slab, the correct measurement of angles of incidence (i), refraction (r) and emergence (e) is shown in diagram

- (a) A.
- (b) B.
- (c) C.
- (d) D.

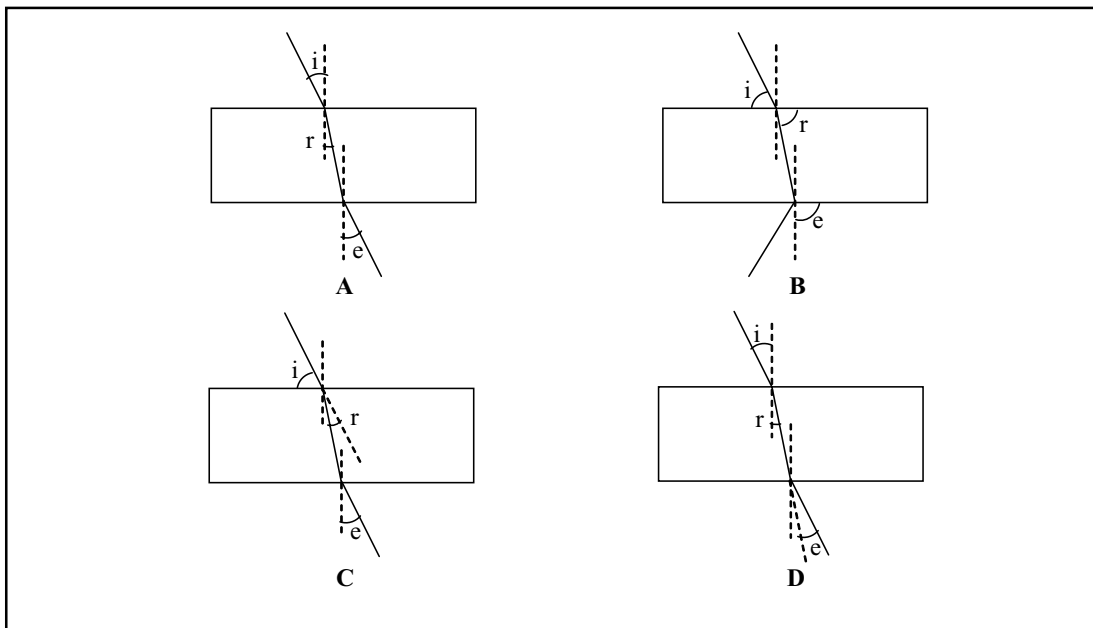

6. The correct set up for studying the dependence of the current on the potential difference across a resistor is
- (a) A.
  - (b) B.
  - (c) C.
  - (d) D.

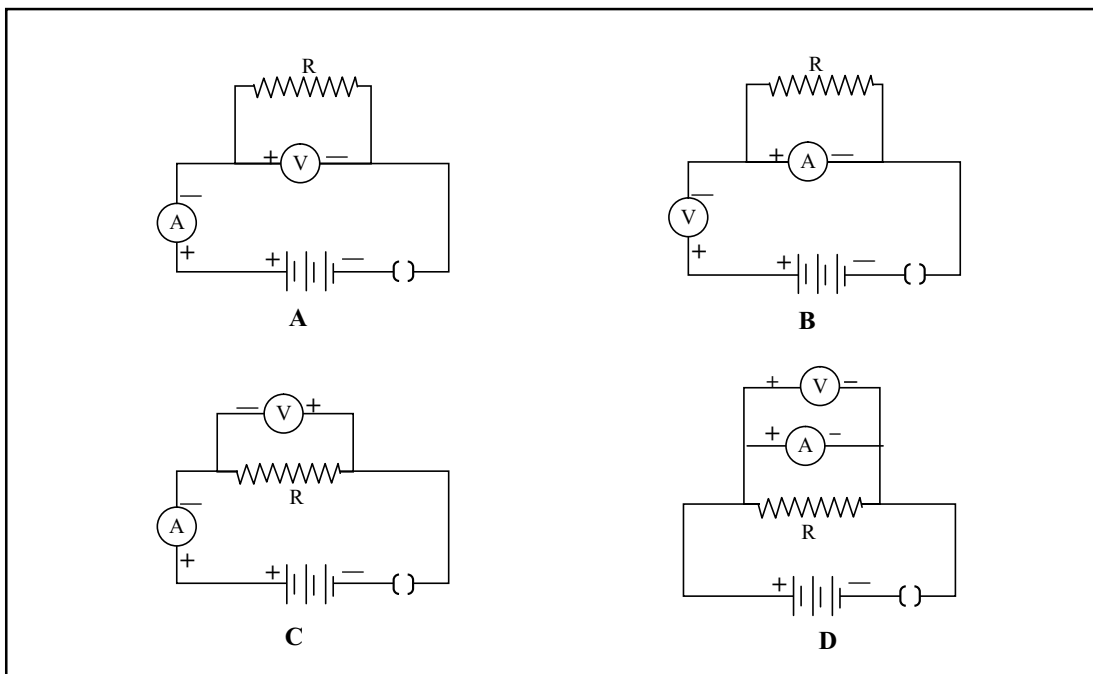

7. In an experiment to determine the focal length of a convex lens, a student obtained a sharp inverted image of a distant tree on the screen behind the lens. She then removed the screen and looked through the lens in the direction of the object. She will see

- (a) an inverted image of the tree at the focus of the lens.
- (b) no image as the screen has been removed.
- (c) a blurred image on the wall of the laboratory.
- (d) an erect image of the tree on the lens.

8. The positive and negative terminal markings are missing from a given battery eliminator. The correct terminal markings can be best identified by the arrangement shown in

- (a) figure 1.
- (b) figures 1 and 2.
- (c) figures 2 and 3.
- (d) figures 3 and 1.

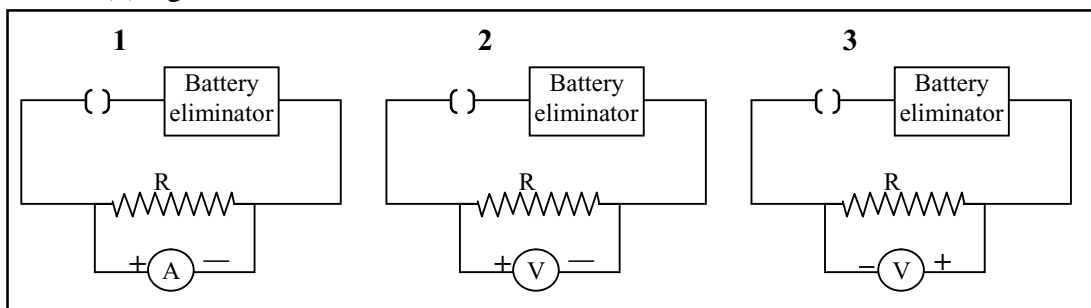

9. In an experiment, to find the equivalent resistance of a series combination of two resistors  $R_1$  and  $R_2$ , a student uses the circuit shown here.

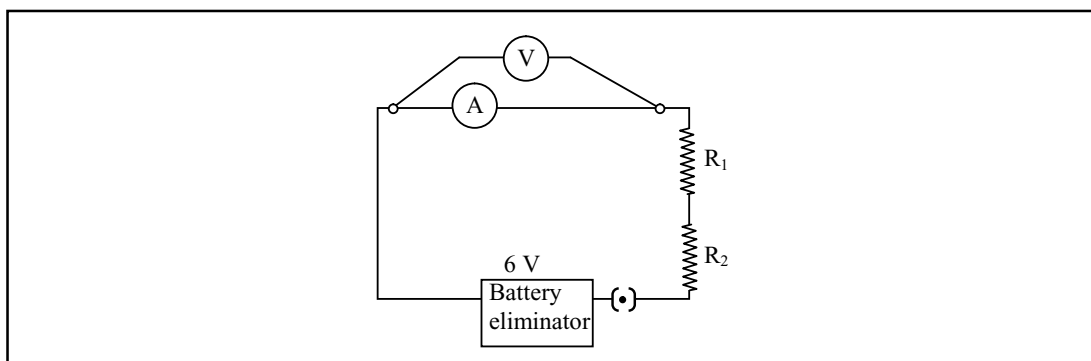

The circuit will give

- (a) correct reading for voltage  $V$ , but incorrect reading for current  $I$ .
- (b) correct reading for current  $I$ , but incorrect reading for voltage  $V$ .
- (c) correct readings for both current  $I$  and voltage  $V$ .
- (d) incorrect readings for both current  $I$  and voltage  $V$ .

10. In an experiment to study dependence of current  $I$  on the potential difference across a given resistor, students kept the plug key in the circuit closed for time  $t_1$  and then open for time  $t_2$ . The times  $t_1$  and  $t_2$  for students P, Q, R and S are given in the table below.

Student	Closed time $t_1$ seconds	Open time $t_2$ , seconds
P	30	60
Q	60	30
R	60	15
S	45	15

The best choice of open and closed times is that of student

- (a) P.
- (b) Q.
- (c) R.
- (d) S.

11. When students observed a stained epidermal peel of a leaf under the microscope, it appeared pinkish red. The stain used was

- (a) iodine.
- (b) acetocarmine.
- (c) safranin.
- (d) colchicin.

12. The process represented in the diagram below is the

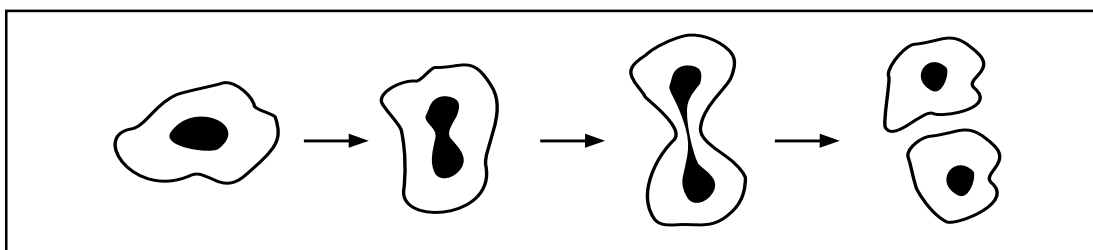

- (a) formation of spores in Amoeba.
- (b) formation of bud taking place in Amoeba.
- (c) identical gametes being formed in Amoeba.
- (d) formation of daughter cells in Amoeba.

13. The following experiment is set up to show that a gas is released during respiration.

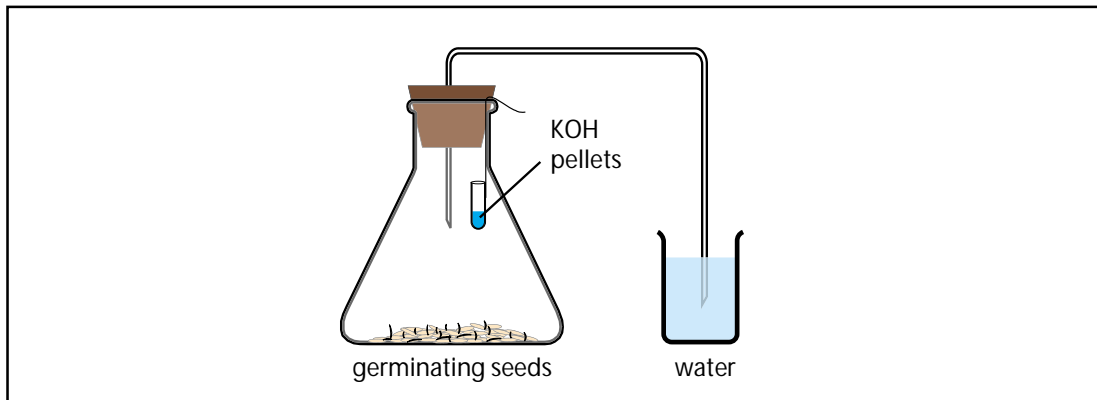

In this set up, the small test tube containing pellets of KOH is kept in the conical flask to absorb

- (a) air in the flask.
- (b) moisture in the flask.
- (c) O<sub>2</sub> in the air in the flask.
- (d) CO<sub>2</sub> released by the germinating seeds.

14. A leaf from a de-starched plant is covered with black paper strip as shown in figure 1. The starch test is done on the leaf after 8 hours.

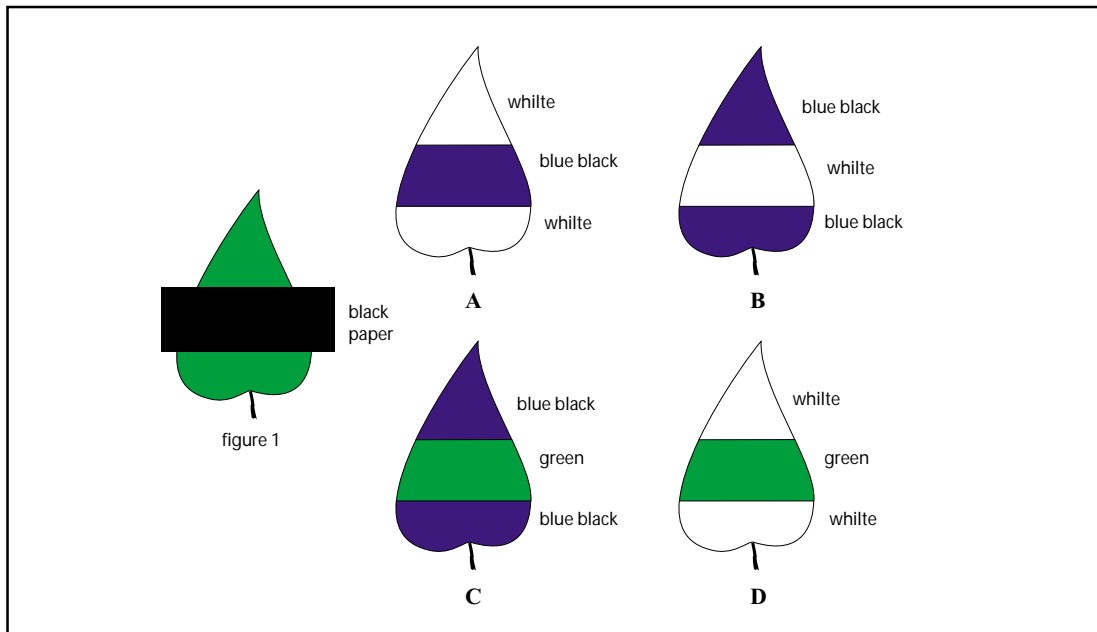

The results will be as shown in diagram

- (a) A.
- (b) B.
- (c) C.
- (d) D.



15. A student dissolved 5 g of sugar in 100 mL of distilled water in beaker A. She dissolved 100 g of sugar in 100 mL of distilled water in beaker B. Then she dropped a few raisins of equal weight in each beaker. After two hours she found the raisins in A swollen and those in B shrunken. The inference drawn is that

- (a) sugar concentration of raisins is lower than that of solution A and higher than that of solution B.
- (b) sugar concentration of raisins is higher than that of solution A and lower than that of solution B.
- (c) in B the cell membrane of raisins was damaged resulting in leaching.
- (d) in A the permeability to water of the cell membrane of raisins was enhanced.

16. The figure given below illustrates the step leading to

- (a) binary fission in Amoeba.
- (b) longitudinal binary fission in Paramecium.
- (c) transverse binary fission in Euglena.
- (d) transverse binary fission in Paramecium.

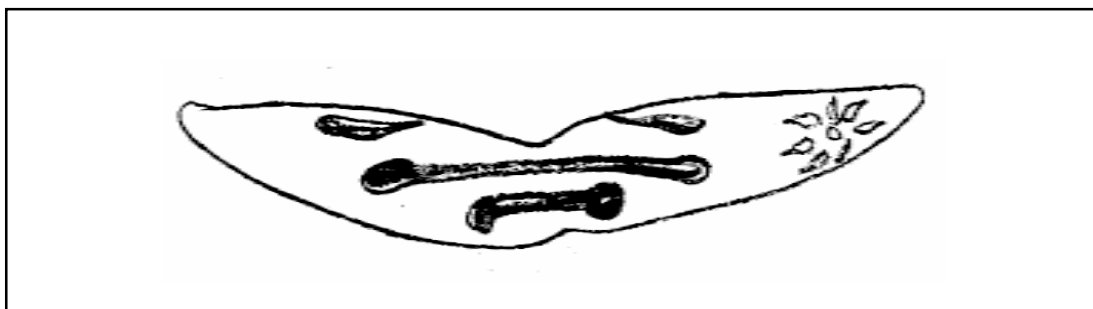

17. Four different arrangements used by students to test the effect of sulphur dioxide on potassium dichromate are shown below.

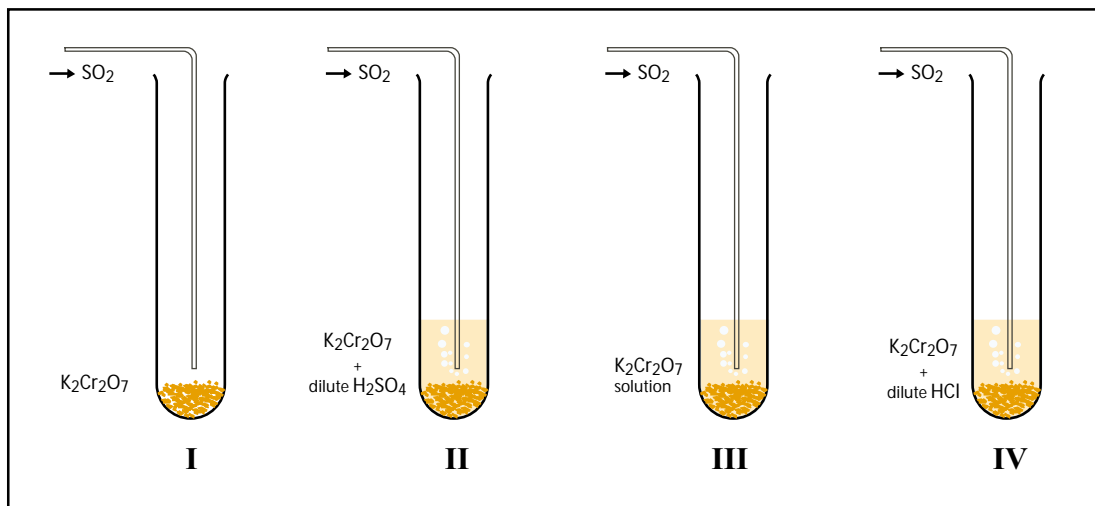

The correct arrangement is shown in

- (a) I.
- (b) II.
- (c) III.
- (d) IV.

18. Four safety symbols are given below.

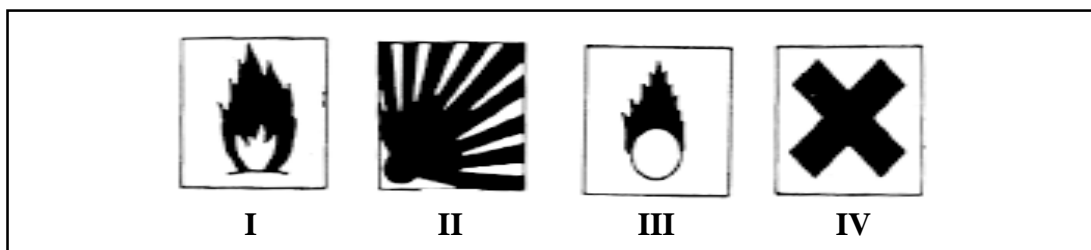

The most appropriate one for sulphur dioxide gas is

- (a) I.
- (b) II.
- (c) III.
- (d) IV.

19. An iron nail was suspended in copper sulphate solution and kept for a while. The solution

- (a) remained blue and a coating was formed on the nail.
- (b) turned green and a coating was found on the nail.
- (c) remained blue and no coating was formed on the nail.
- (d) turned green and no coating was formed on the nail.

20. The most appropriate method of testing the odour of a given liquid is

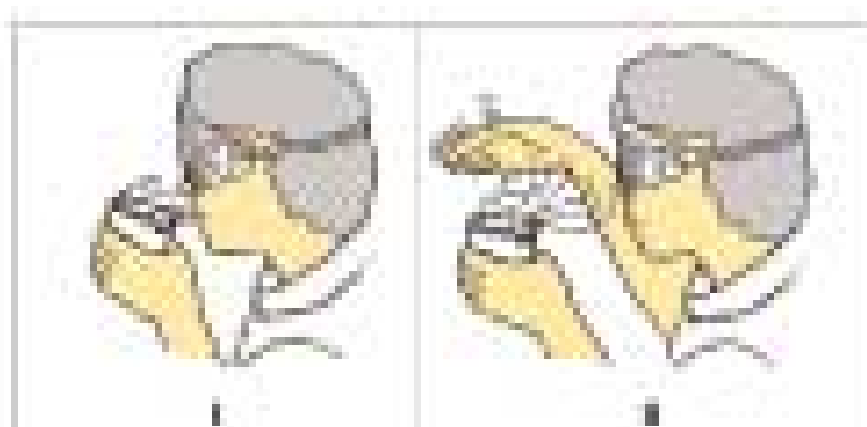

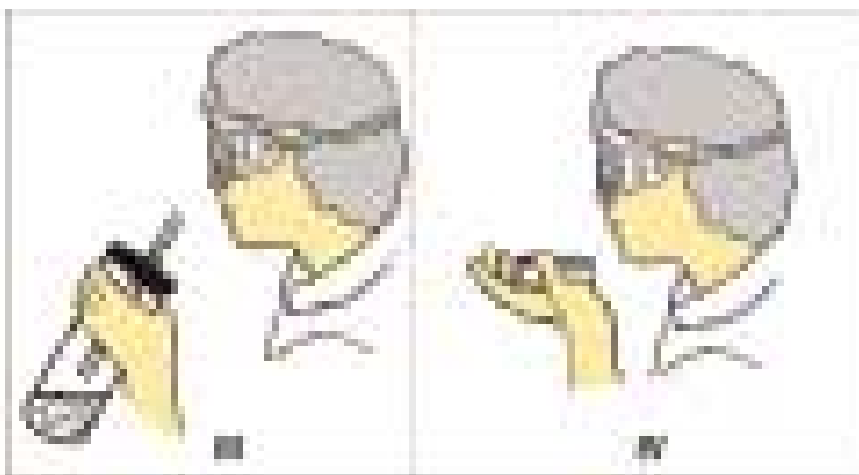

- (a) I.
- (b) II.
- (c) III.
- (d) IV.

## SECTION B

21. A student was given three samples containing ethanoic acid, sodium bicarbonate solution and water in test tubes I, II and III, respectively. On dipping a pH paper in them, he observed that the colour turned orange in I, blue in II and green in III. If arranged in increasing order of their pH, the sequence of these bottles would be

- (a) I, III, II.
- (b) I, II, III.
- (c) III, I, II.
- (d) II, III, I.

22. The following apparatus is available in the laboratory

Battery : adjustable from 0 to 6 V

Resistors :  $3\Omega$  and  $6\Omega$

Ammeters : A1 of Range 0 to 5 A; Least Count 0.25 A

A2 of Range 0 to 3 A; Least Count 0.1 A

Voltmeters : V1 of Range 0 to 10 V; Least Count 0.5 V

V2 of Range 0 to 5 V; Least Count 0.1 V

For the experiment to find the equivalent resistance of the parallel combination of the two given resistors, the best choice would be

- (a) ammeter A1 and voltmeter V1.
- (b) ammeter A1 and voltmeter V2.
- (c) ammeter A2 and voltmeter V1.
- (d) ammeter A2 and voltmeter V2.

23. In an experiment to trace the path of a ray of light passing through a rectangular glass slab, four students tabulated their observations as given below.

S.No.	Angle of incidence degree	Angle of refraction degree	Angle of emergence degree
1	30	18	32
2	45	28	43
3	60	35	60

S.No.	Angle of incidence degree	Angle of refraction degree	Angle of emergence degree
1	30	15	38
2	45	20	53
3	60	28	67

S.No.	Angle of incidence degree	Angle of refraction degree	Angle of emergence degree
1	30	10	31
2	45	15	44
3	60	22	60

S.No.	Angle of incidence degree	Angle of refraction degree	Angle of emergence degree
1	30	28	28
2	45	40	40
3	60	56	56

The student most likely to have done the experiment properly is

- (a) A.
- (b) B.
- (c) C.
- (d) D.

24. For the circuits A and B shown below, the voltmeter readings would be

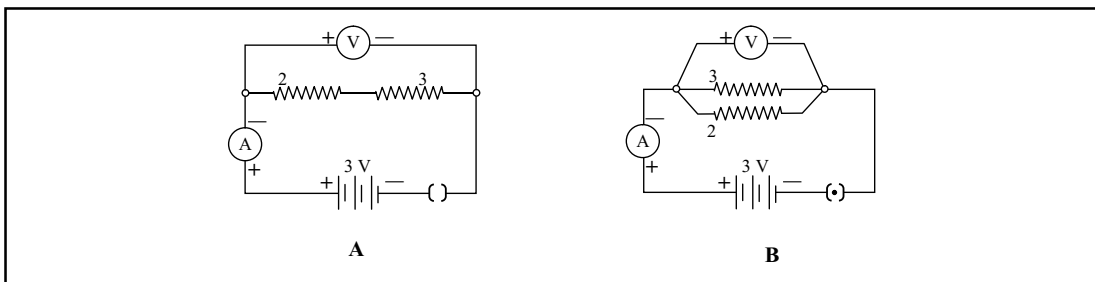

- (a) 0.6 V in circuit A and 2.5 V in circuit B.
- (b) 0 V in both circuits.
- (c) 3 V in both circuits.
- (d) 0 V in circuit A and 3 V in circuit B.

25. Two of the following four figures that illustrate budding are

- (a) 1 and 2.
- (b) 1 and 3.
- (c) 1 and 4.
- (d) 2 and 4.

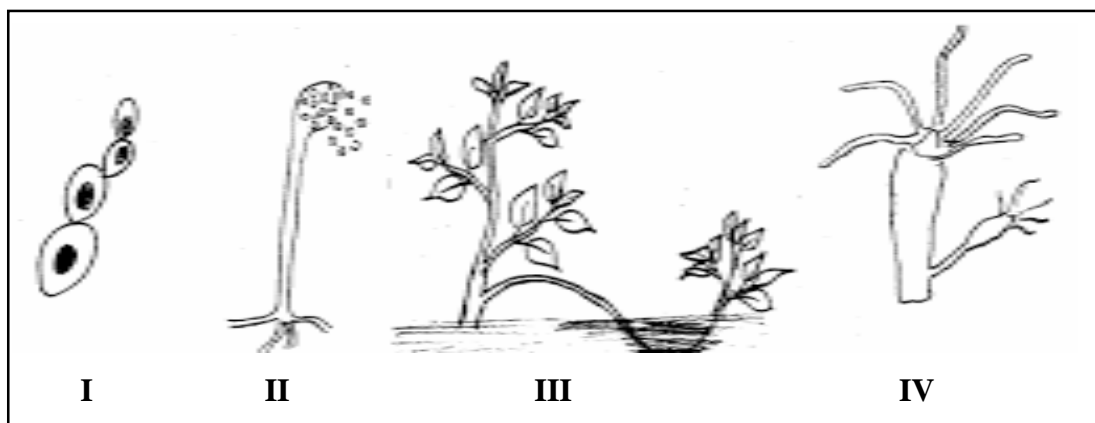

26. The correct procedure to prepare a temporary mount of a stained leaf epidermis is

A	B	C	D
Take a peel of a leaf; Stain it with safranin; Transfer the peel to the slide; Remove the excess stain; Put a cover slip on it.	Take a peel of a leaf; Wash it in water; Place it on the slide; Add a drop of glycerin on it; Put a cover slip gently.	Stain the leaf; Take a peel; Wash the peel in water; Place it on a slide; Put a cover slip on it.	Take a peel; Stain it with iodine; Transfer the peel to the slide; Remove excess stain with blotting paper; Put a cover slip on it.

- (a) A.
- (b) B.
- (c) C.
- (d) D.

27. While performing an experiment with raisins, a student recorded the following data.

Mass of water taken in the beaker = 50 g  
 Mass of raisins before soaking = 20 g  
 Mass of raisins after soaking = 30 g  
 Mass of water in the beaker left after experiment = 40 g  
 The % of water absorbed by the raisin is

- (a) 10 %.
- (b) 20 %.
- (c) 45 %.
- (d) 50 %.

28. Using the same number of given germinating gram seeds, two students A and B set up the experiment separately. Student A used a cotton plug to hold the bent tube in the mouth of the flask. Student B used a rubber cork.

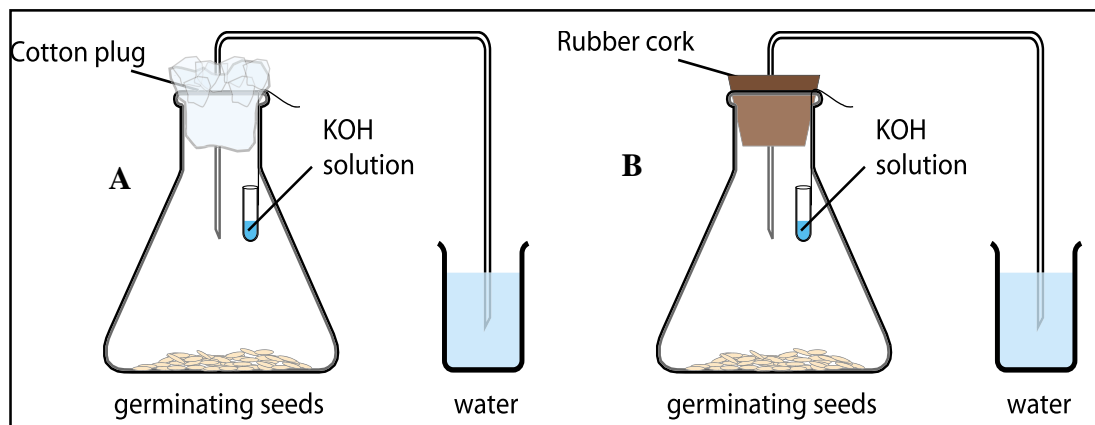

After 4 hours they noticed that

- water level increased in the bent tube only of A.
- water level increased in the bent tube only of B.
- the cotton plug was wet.
- the water in the beaker of B turned milky.

29. The proper experimental arrangement to collect sulphur dioxide is as shown in

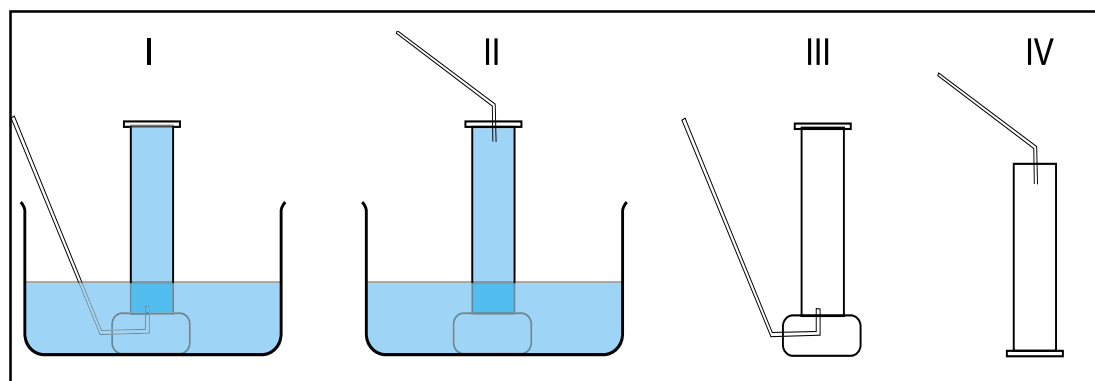

- I.
- II.
- III.
- IV.

30. To show that zinc is more reactive than copper, the correct procedure is to

- prepare copper sulphate solution and dip zinc strip in it.
- prepare zinc sulphate solution and dip copper in it.
- heat zinc and copper strips.
- add dilute nitric acid on both the strips.

### Question-wise Analysis and Scoring Key for Sample Paper III

Q.No	Expt. No.	Correct choice	Skills Tested	Explanation/ Remarks
1.	1	(c)	P	For testing pH, aqueous solutions are used.
2.	2	(d)	P, M	Since red litmus shows no colour change with acids, it is first to be changed to blue litmus
3.	2	(d)	P, D	Zinc reacts with sodium hydroxide on heating to produce hydrogen gas rapidly.
4.	3	(c)	O	The sharp inverted vertical image of the distant tree is formed by a concave mirror.
5.	3	(a)	D, I	All the three angles, shown, here have to be measured with respect to the normal drawn at the points of incidence/ emergence.
6.	5	(a)	P	The ammeter has to be put in series and the voltmeter in parallel, with the resistor, with both instruments connected with their polarities also correct.
7.	3	(a)	O, I	The screen is just a device to observe the (real) image formed by a convex lens. The image of a distant object continues to get formed at the focus of the convex lens even when no screen is being used to show its formation.
8.	5(6, 7)	(c)	P, I	We can connect only the voltmeter (a high resistance device) in parallel with the resistor R. An ammeter, (a very low resistance device) would reduce the overall resistance of the circuit to almost zero. This would damage not only the ammeter but also the battery eliminator.
9.	5 (6,7)	(b)	P, I	The voltmeter has to be put in parallel with the resistances being measured and not across the ammeter.
10.	6 (5, 7)	(a)	P, I	We must keep the circuit closed for a relatively shorter time and open for a relatively longer time. This would ensure minimal changes in the values of resistances due to the heating effects of currents.
11.	8	(c)	P, O	Safranin is pinkish red in colour.
12.	11	(d)	O, D	The sequence illustrates binary fission in Amoeba.
13.	10	(d)	P, O, R	KOH absorbs CO <sub>2</sub> released by the seeds.
14.	9	(b)	O, R	Sunlight is not available to the covered portion. Hence no starch. Remains white after starch test. The rest is stained.
15.	12	(b)	R	A is hypotonic to the sap of raisin. B is hypertonic. Hence endosmosis in A and exosmosis in B.
16.	11	(d)	O, D	Transverse fission in Paramecium.
17.	13	(b)	O, I, D	SO <sub>2</sub> reduces acidified K <sub>2</sub> Cr <sub>2</sub> O <sub>7</sub> and the most suitable acid used for acidification in dil H <sub>2</sub> SO <sub>4</sub>
18.	13	(d)	O, P	SO <sub>2</sub> is irritant/harmful
19.	14	(b)	O, I	Iron being more reactive displaces copper from copper sulphate.
20.	15	(b)	P	The gases should not be smelt directly or kept too close to nose.
21.	1	(a)	O, I	Ethanoic acid has the lowest pH and NaHCO <sub>3</sub> has the highest pH whereas pH of water is in between the two

22.	7	(c)	P, I	The equivalent resistance of 3 and 6 , in parallel is 2 . The current in the circuit can, therefore, go only up to 3 A. We therefore choose instruments of correct range and a better least count.
23.	4	(a)	O, R	We must not only have the angle of emergence (nearly) equal to the angle of incidence but also have an idea of the magnitude of the angle of refraction (for a glass slab) for the three most often used values (30°, 45°, 60°) of the angle of incidence.
24.	6, 7	(d)	D, I	Only circuit B, with a dot within the symbol of the plug key, is a closed circuit in which current is flowing and will show non-zero voltage. The voltmeter reading, for the set ups shown, would be(nearly) equal to the voltage of the battery.
25.	11	(c)	O, D	Yeast and Hydra reproduce by budding.
26.	8	(a)	P	Proper procedure to prepare a good stained temporary mount of leaf peel.
27.	12	(d)	R	Calculation using the formula.
28.	10	(b)	P	The conical flask should be closed with rubber cork to make it air tight. Otherwise partial vacuum will not be created.
29	13	(d)	M, P, D	SO <sub>2</sub> is soluble in water and heavier than air.
30.	14	(a)	P	Zinc displaces copper from its salt solution.





## Acknowledgements

The board thankfully acknowledges the rich contributions made by the following experts in developing this document.

Prof. Arvind Kumar

Prof. Chitra Natarajan

Dr. N. K. Sehgal

Prof. S. C. Agarkar

Shri. V. G. Gambhir

Prof. Sunita Malhotra

Mr. Virender Srivastava

Mr. V. D. Lale

Ms. Vijayalakshmi Srivatsan

Ms. Margarette Davidraj

Mr. V. C. Sonawane

Mr. N. D. Deshmukh

Shri G. Balasubramaniam  
Director (Academic) CBSE

Shri R. P. Sharma  
Education Officer (Science)  
(Co-ordinator)